

Section A

Answer any **two** questions from **one** of the Parts **A**, **B** or **C**.

Part A – Product Design

1

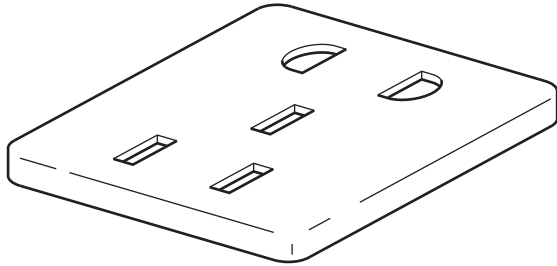

item: thermoplastic plug socket
process: compression moulding

item: aluminium bracket
process: milling

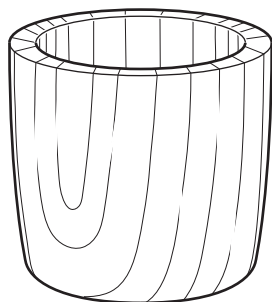
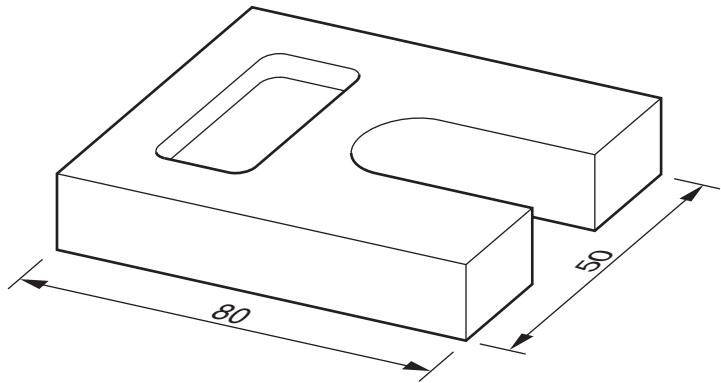

item: wooden egg cup
process: turning

Fig. 1.1

Choose **two** of the items shown in Fig. 1.1 and for each:

- (a) use notes and sketches to describe how the process has been used in the manufacture of the item [14]
- (b) explain why the process is particularly suitable in the production of the item. [6]

2 Fig. 2.1 shows details of a child's easel.

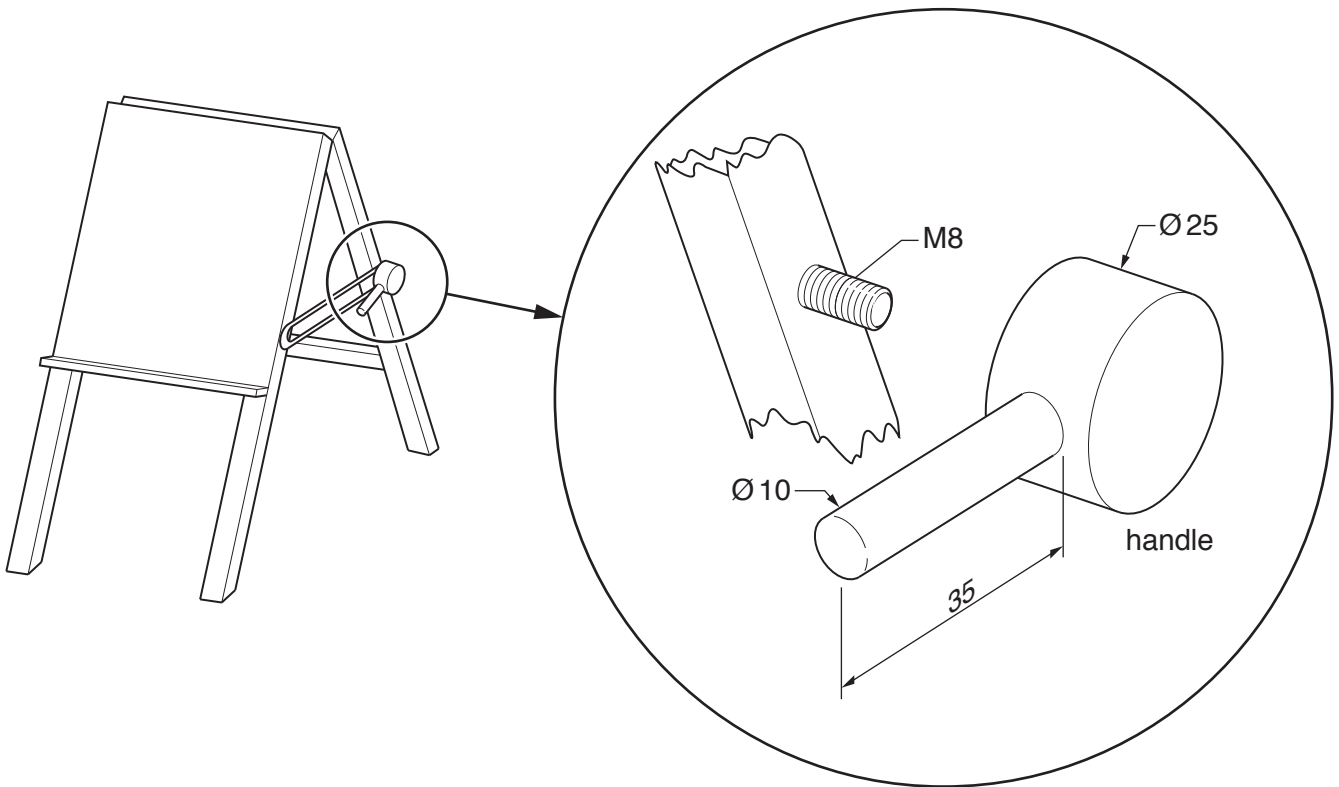

Fig. 2.1

- (a) State a suitable material for a handle of the type shown in Fig. 2.1 and give **two** reasons for your choice. [3]
- (b) Describe, using notes and sketches, how you would make one handle. [9]
- (c) Explain the changes that may be necessary to the design, the manufacturing method used and the material selected, if 5000 identical handles were required. Use notes and sketches to support your answer. [8]
- 3 Discuss the influence of economic factors on the design, manufacture and marketing of a product of your own choice. [20]

Part B – Practical Technology

- 4 (a) Use notes and sketches to compare and contrast the processes of **blow moulding** and **rotational moulding**.

Use examples of products manufactured by each process to support your answer. [10]

- (b) Discuss the impact of technological developments on the manufacture of products. [10]

- 5 Fig. 5.1 shows forces acting on a point on a beam.

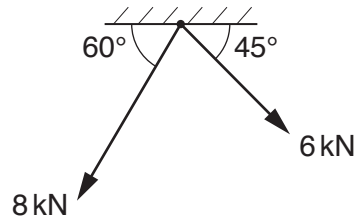

Fig. 5.1

- (a) Determine the direction and magnitude of the force. [2]

- (b) Explain the following terms with reference to mechanisms:

- effort
- velocity ratio.

[4]

- (c) Fig. 5.2 shows a gear train.

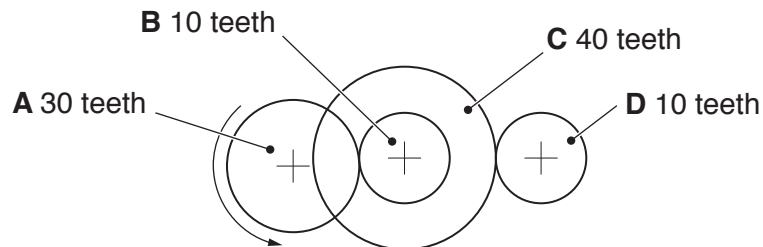

Fig. 5.2

- (i) Gear **A** rotates anticlockwise. State the direction of rotation of gear **D**. [1]

- (ii) Calculate the gear ratio of the compound gear train shown in Fig. 5.2. [3]

- (d) Discuss the drawbacks and benefits of friction when a car is being used. [10]

- 6 Explain the working of **five** of the following. For each, give an application of its use.

- Light Dependent Resistor
- strain gauge
- reed switch
- thermistor
- Darlington Pair
- Schmitt trigger

[20]

Part C – Graphic Products

- 7 Fig. 7.1 shows an incomplete drawing of the intersection of an hexagonal prism and a square prism.

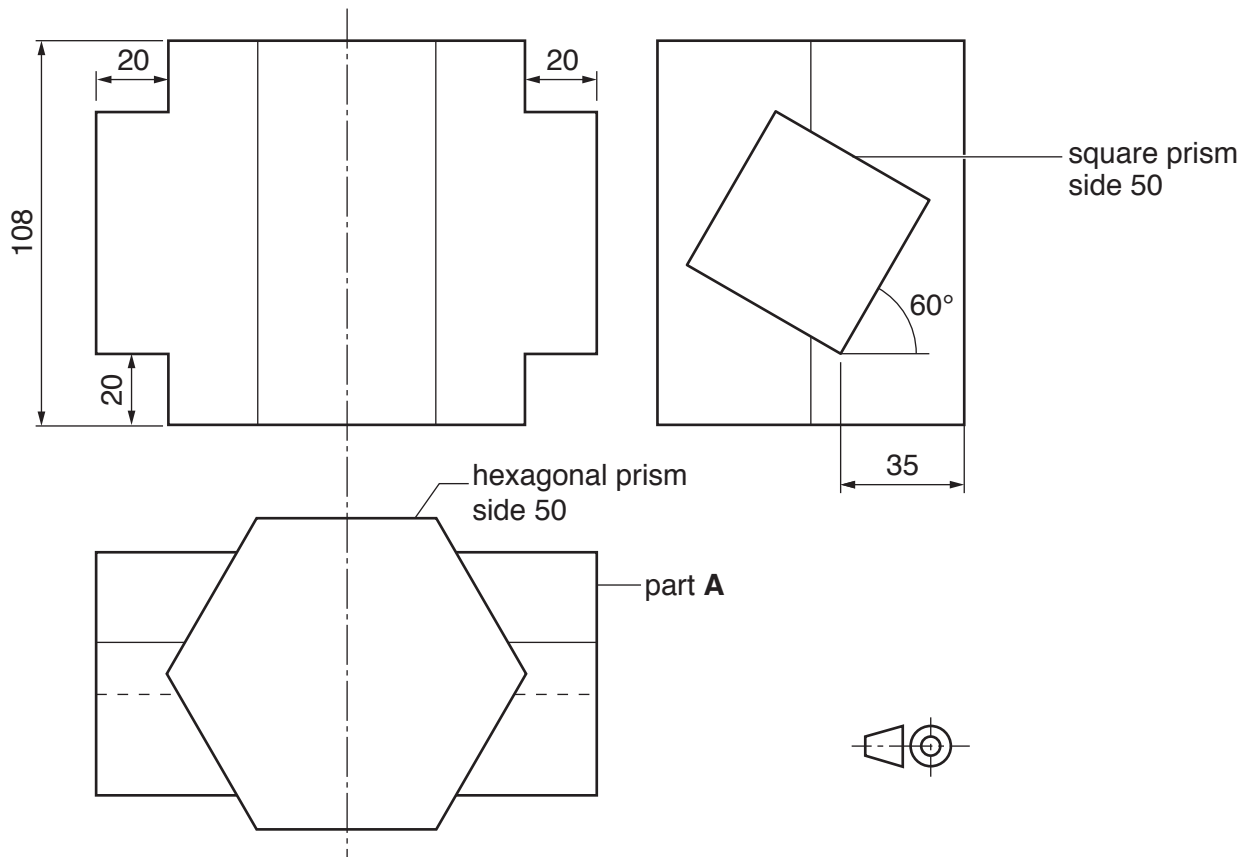

Fig. 7.1

Draw to a scale of 1:2:

- (a) the given orthographic views and complete the lines of intersection [12]
- (b) the development (net) of Part **A** of the square prism. [8]
- 8 (a) Describe how the following are used by a designer. Use examples to support your answer.
- 2D/3D modelling
 - scale models [8]
- (b) Explain **two** benefits of using CAD when designing graphic products. Use examples to support your answer. [8]
- (c) Explain the importance to a designer of researching existing products. [4]

9 Fig. 9.1 shows the design for a bus shelter.

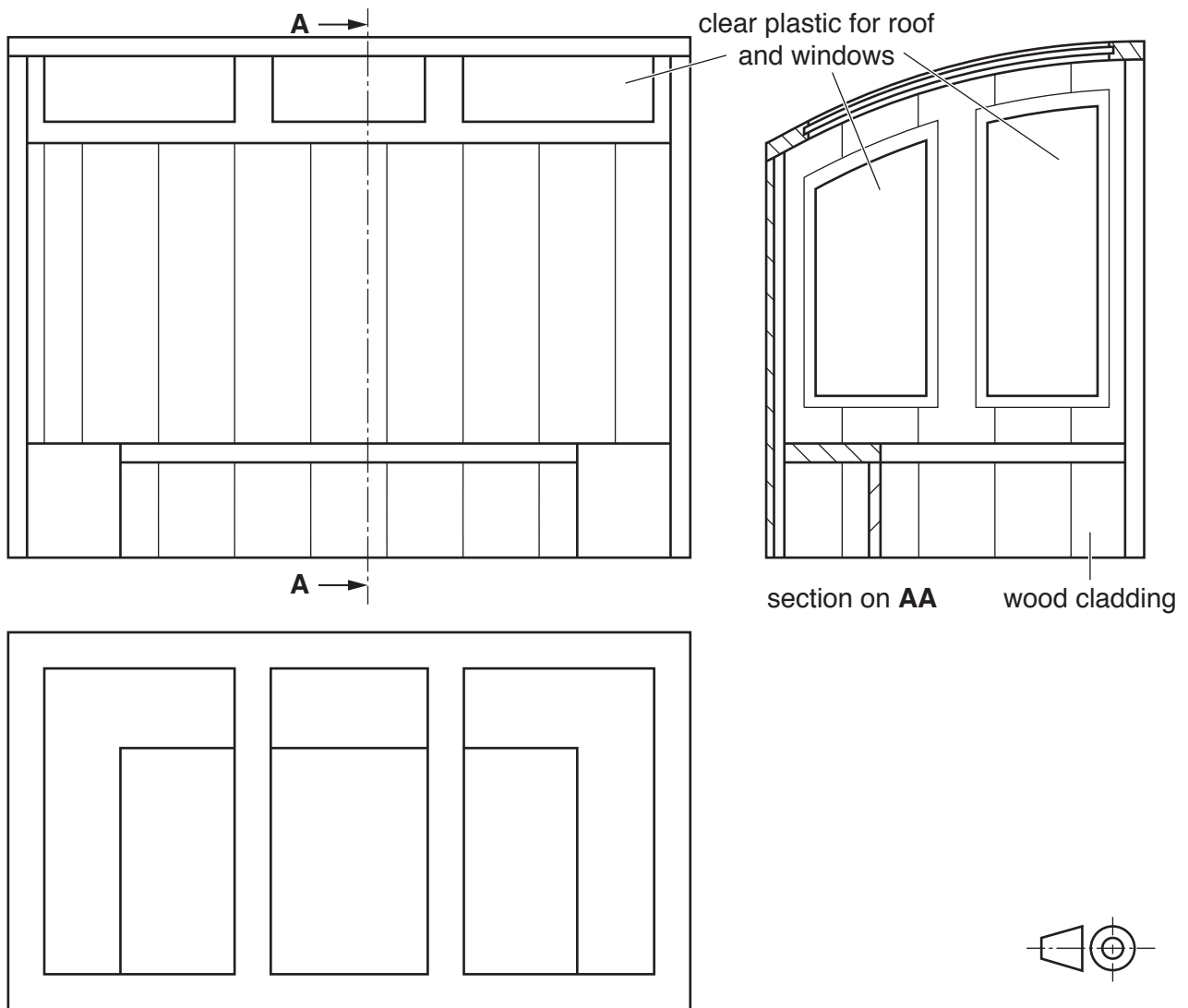

Fig. 9.1

(a) Draw a complete estimated two-point perspective view of the bus shelter. [16]

(b) Render the drawing to show the different materials from which the shelter would be made. [4]

Section B

Answer **one** question on the A3 paper provided.

Each question is worth 80 marks.

You should approach the design question of your choice in the following manner:

Analysis

Produce an analysis of the given situation/problem, which may be in written or graphical form. [5]

Specification

From the analysis produce a detailed written specification of the design requirements. Include at least five specification points other than those given in the question. [5]

Exploration

Use bold sketches and brief notes to show your exploration of ideas for a design solution, with reasons for selection. [25]

Development

Show using bold sketches and notes, the development, reasoning and composition of ideas into a single design proposal. Give details of materials, constructional and other relevant technical details. [25]

Proposed solution

Produce drawings of an appropriate kind to show the complete solution. [15]

Evaluation

Give a written evaluation of the final design solution. [5]

10 Washing up after meals can be very difficult on camping holidays with large family groups.

A product that would enable a family to wash and dry pans, plates and cutlery after meals is required.

The product must be:

- able to stand on uneven ground
- stored away easily for transport.

[80]

11 A sports club uses plastic cones to mark out areas for training exercises. It is very time consuming and physically uncomfortable picking up large amounts of cones at the end of training sessions.

Design a device to pick up the cones.

The device must be:

- easy to operate
- able to be used by adults and children.

Details of the cone are shown in Fig. 11.1.

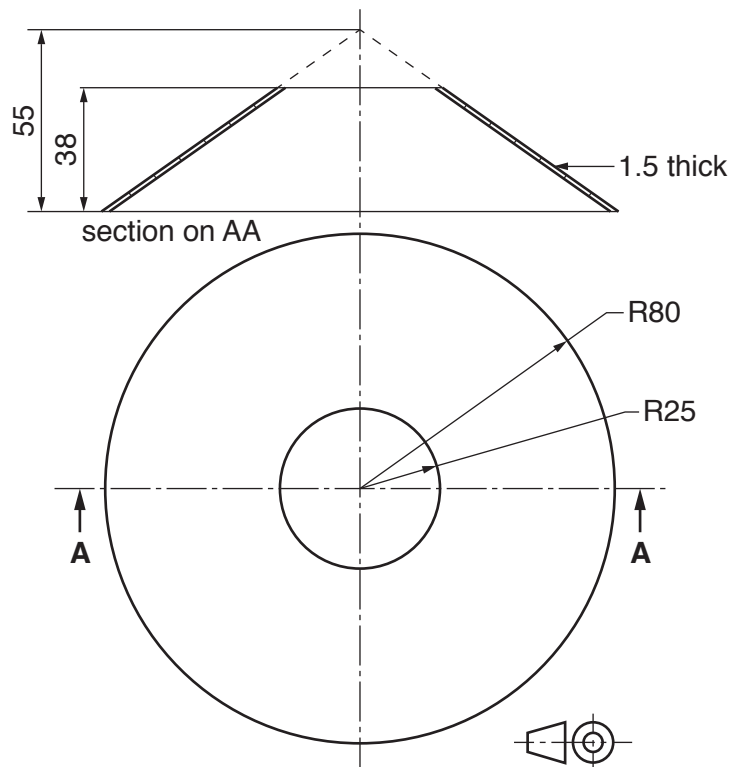

Fig. 11.1

[80]

12 A garden centre wishes to sell a package of four pots of herbs.

You are to design packaging that will:

- protect the four pots of herbs
- enable customers to easily carry the four pots of herbs
- include a product name of your choice and a logo.

To assist you in your answer, details of a pot and examples of the shapes of herb leaves are given in Fig. 12.1.

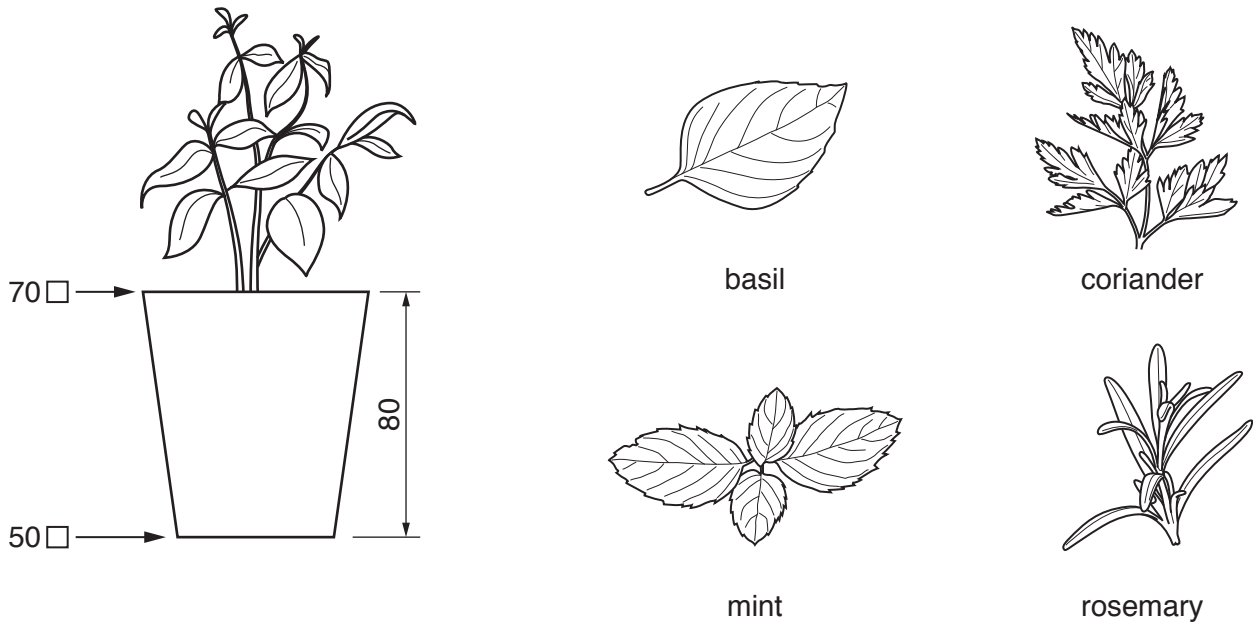

Fig. 12.1

[80]

BLANK PAGE

Permission to reproduce items where third-party owned material protected by copyright is included has been sought and cleared where possible. Every reasonable effort has been made by the publisher (UCLES) to trace copyright holders, but if any items requiring clearance have unwittingly been included, the publisher will be pleased to make amends at the earliest possible opportunity.

To avoid the issue of disclosure of answer-related information to candidates, all copyright acknowledgements are reproduced online in the Cambridge Assessment International Education Copyright Acknowledgements Booklet. This is produced for each series of examinations and is freely available to download at www.cambridgeinternational.org after the live examination series.

Cambridge Assessment International Education is part of the Cambridge Assessment Group. Cambridge Assessment is the brand name of the University of Cambridge Local Examinations Syndicate (UCLES), which itself is a department of the University of Cambridge.