



## Cambridge O Level

CANDIDATE  
NAME

--

CENTRE  
NUMBER

--	--	--	--	--

CANDIDATE  
NUMBER

--	--	--	--



**DESIGN & TECHNOLOGY**

**6043/32**

Paper 3 Resistant Materials

**October/November 2023**

**1 hour**

You must answer on the question paper.

No additional materials are needed.

### INSTRUCTIONS

- Section A: answer **all** questions.
- Section B: answer **one** question.
- Use a black or dark blue pen. You may use an HB pencil for any diagrams or graphs.
- Write your name, centre number and candidate number in the boxes at the top of the page.
- Answer in the space provided.
- Do **not** use an erasable pen or correction fluid.
- Do **not** write on any bar codes.
- You may use a calculator.

### INFORMATION

- The total mark for this paper is 50.
- The number of marks for each question or part question is shown in brackets [ ].
- All dimensions are in millimetres.

This document has **24** pages. Any blank pages are indicated.

Section A

Answer **all** questions in this section.

1 Fig. 1.1 shows a garden wheelbarrow.

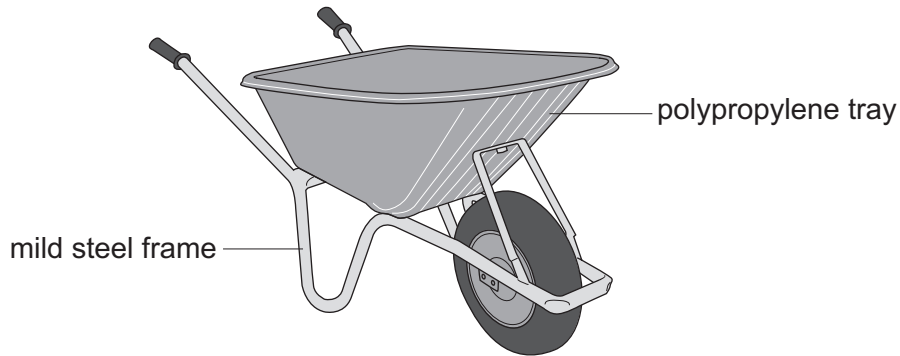

Fig. 1.1

Identify **three** design features that would help the consumer when using the garden wheelbarrow.

- 1 .....
- 2 .....
- 3 .....

[3]

2 Fig. 2.1 shows exploded views of a finger (comb) joint marked out and cut out.

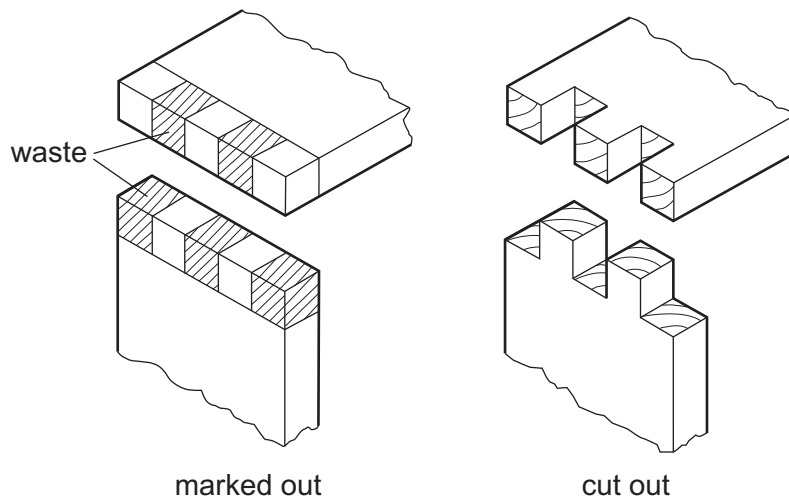

Fig. 2.1

Name **two** different saws that could be used to remove the waste wood.

- 1 .....
- 2 .....

[2]

- 3 Fig. 3.1 shows two parts of a shelving system. The upright is screwed to a wall and the bracket slots into the upright to support a wooden shelf.

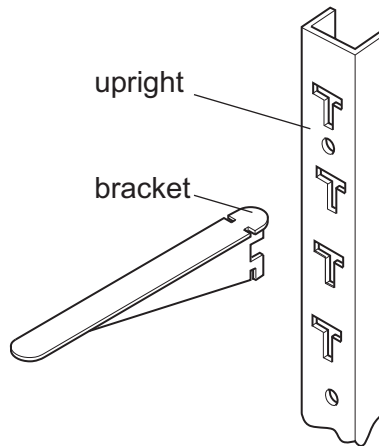
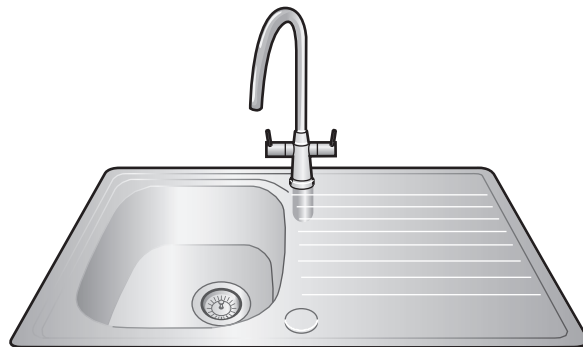

**Fig. 3.1**

Use sketches and notes to show a modification to the bracket so that the shelf could be held more securely.

[2]

- 4 Fig. 4.1 shows a sink unit made from stainless steel.



**Fig. 4.1**

- (a) State **one** property of stainless steel that makes it suitable for the sink unit.

..... [1]

- (b) Stainless steel is an alloy. Give the name of **one** metal that is added to steel to make stainless steel.

..... [1]

5 Fig. 5.1 shows a gate fixed to a wall. The frame of the gate has started to collapse.

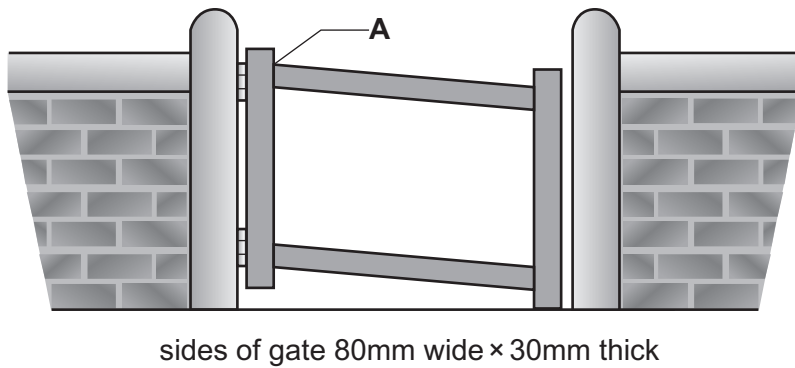

**Fig. 5.1**

(a) Name a suitable joint that could be used to join the sides of the gate at corner **A**.

..... [1]

(b) Name a suitable type of hinge that could be used to 'hang' the gate.

..... [1]

(c) Add sketches and notes to Fig. 5.1 to show how the frame of the gate could have been prevented from collapsing. [2]

6 Fig. 6.1 shows two pieces of 5 mm thick mild steel, **A** and **B**.

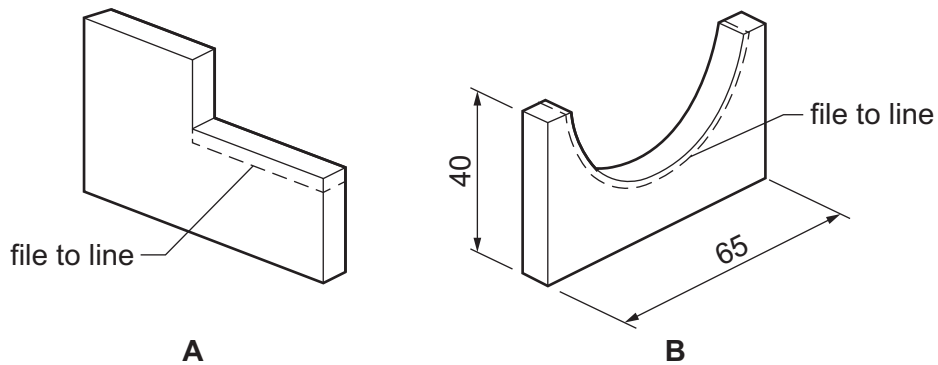

**Fig. 6.1**

Name a specific file that could be used to remove the waste metal to the line shown in the mild steel:

**A** .....

**B** .....

[2]

7 Fig. 7.1 shows an exploded view of a hand-held torch showing the different parts.

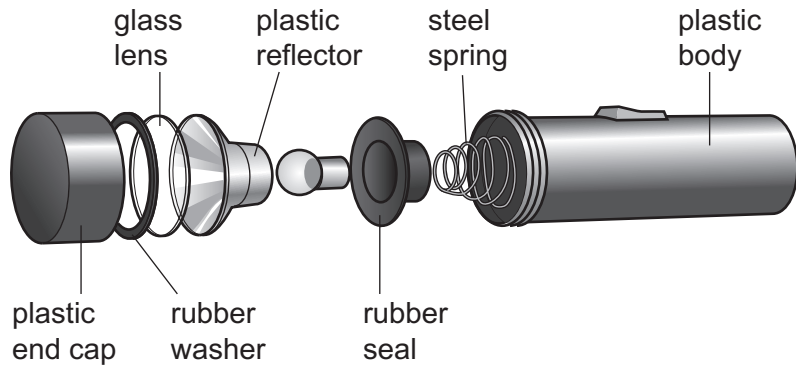
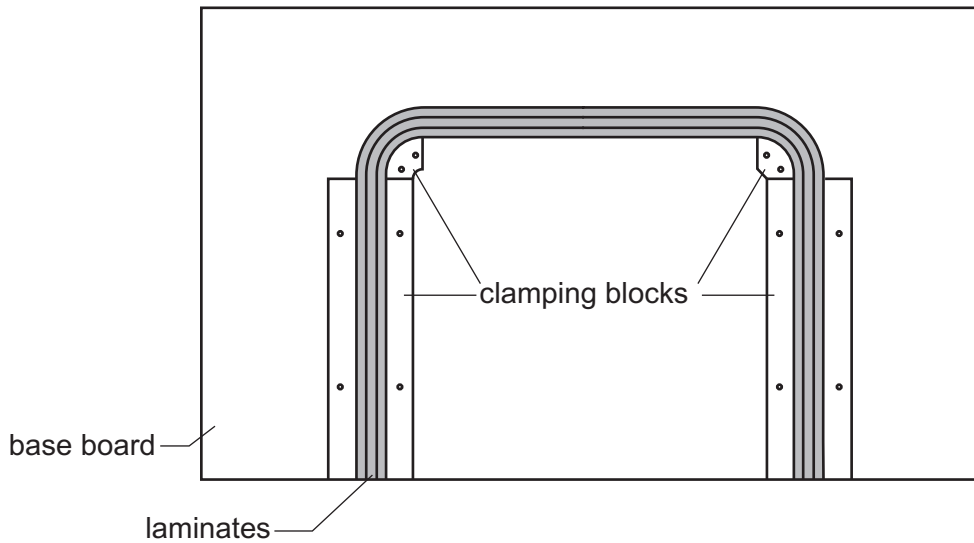

**Fig. 7.1**

Give **two** benefits to the environment of designing products that can be disassembled.

- 1 .....
  - 2 .....
- [2]

8 Fig. 8.1 shows legs of a small table that have been produced by laminating veneers.



**Fig. 8.1**

Add sketches and notes to Fig. 8.1 to show the remaining clamping blocks required to ensure that the legs are successfully laminated. [4]

9 Select from the list below the metal that corresponds to the description.

**mild steel    brass    lead    cast iron    copper**

(a) Pure metal, good conductor of heat and electricity, easily soldered, corrosion resistant.

..... [1]

(b) Pure metal, heaviest metal, soft, malleable, excellent chemical resistance.

..... [1]

10 Fig. 10.1 shows a sectional view through part of a vacuum forming machine and a wooden mould that will be used when vacuum forming the thermoplastic sheet.

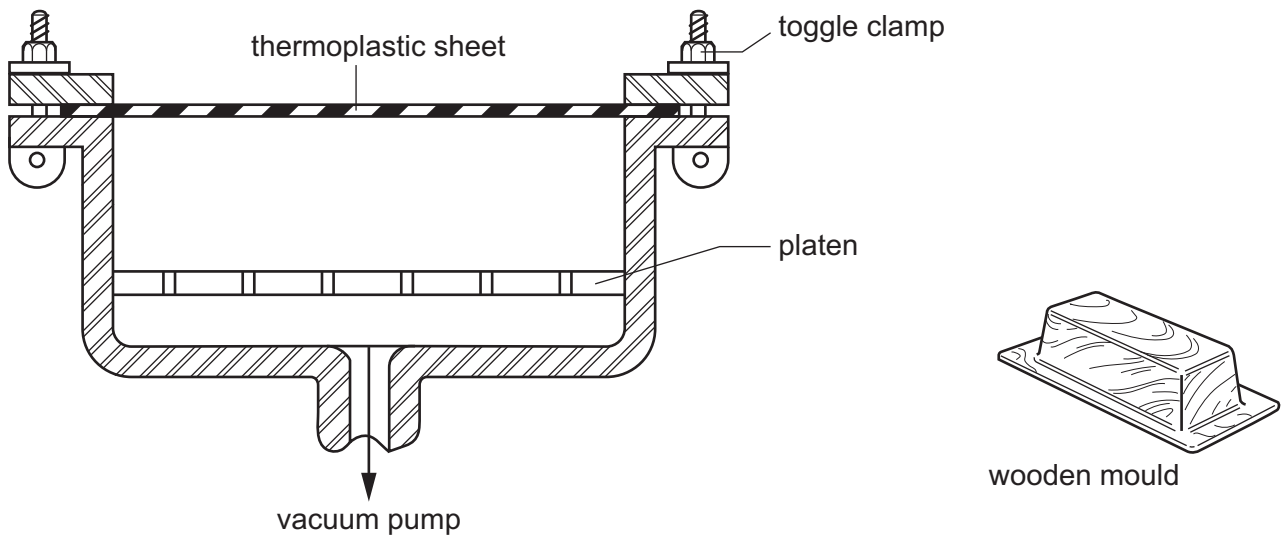

**Fig. 10.1**

Add sketches and notes to the vacuum forming machine shown in Fig. 10.1 to show the position of:

(a) the heater

(b) the wooden mould.

[2]

**Section B**

Answer **one** question from this section.

- 11 Fig. 11.1 shows an incomplete design for a paint holder that will be used when painting from a ladder.

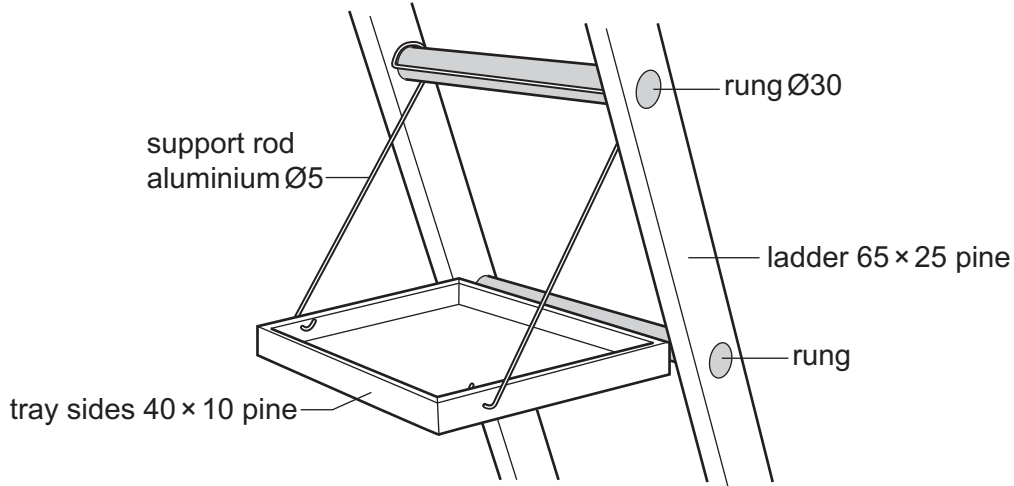

**Fig. 11.1**

- (a) State **three** items of research the designer would need to consider when designing the paint holder.

1 .....

2 .....

3 .....

[3]

- (b) Give **two** properties of aluminium that make it suitable for the support rods.

1 .....

2 .....

[2]

- (c) Fig. 11.2 shows details of the tray in which tins of paint and brushes could be placed while painting from the ladder. Mitre joints are used to join the sides at each corner of the tray.

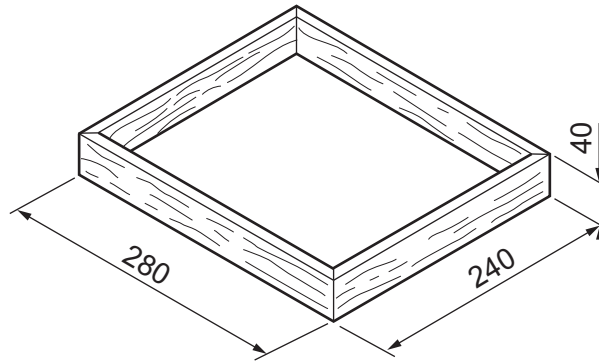

Fig. 11.2

Use sketches and notes to show how **one** mitre joint could be marked out and cut out. Name the tools and equipment used to produce the mitre joint.

[4]

- (d) Fig. 11.3 shows two constructions, **A** and **B**, that could be used to fit a 6 mm thick plywood base to the tray.

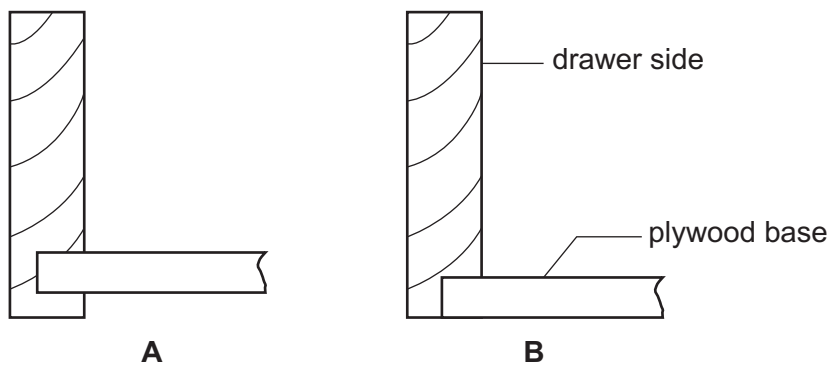

Fig. 11.3

- (i) State the name of each method of construction, **A** and **B**.

Construction **A** .....

Construction **B** .....

[2]



(ii) State **two** advantages of using construction **A** rather than construction **B** to fit the plywood base to the tray.

1 .....

2 .....

[2]

(e) Fig. 11.4 shows views of the tray and an incomplete support rod. The rod has been bent to fit the tray but the bend to fit around the top rung has yet to be produced.

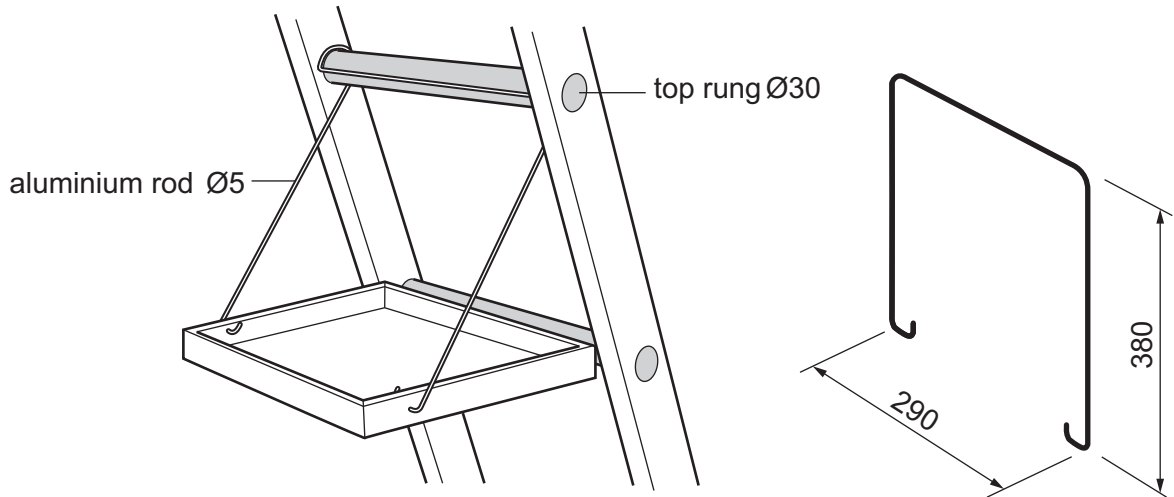

**Fig. 11.4**

Use sketches and notes to show how the bend to fit around the top rung could be produced. Name the tools and equipment used to produce the bend.

[4]

- (f) Fig. 11.5 shows a sectional side view of the ladder with the paint holder in position. In use the tray must be supported by the lower rung.

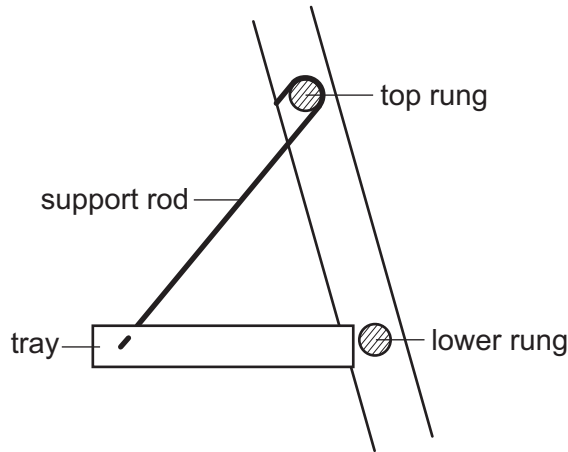

Fig. 11.5

Use sketches and notes to show how the tray could be supported by the lower rung. Include details of all materials and constructions used.

[4]

- (g) The paint holder will be used outdoors. Identify **two** problems facing designers of products that are used outdoors. Describe how the problems can be overcome.

Problem 1 .....

.....

How overcome .....

.....

Problem 2 .....

.....

How overcome .....

.....

[4]

- 12 A Design and Technology student has been asked by a local nursery to design a chair suitable for children aged 3–4 years old.  
A prototype of the chair made from 15 mm thick MDF is shown in Fig. 12.1.

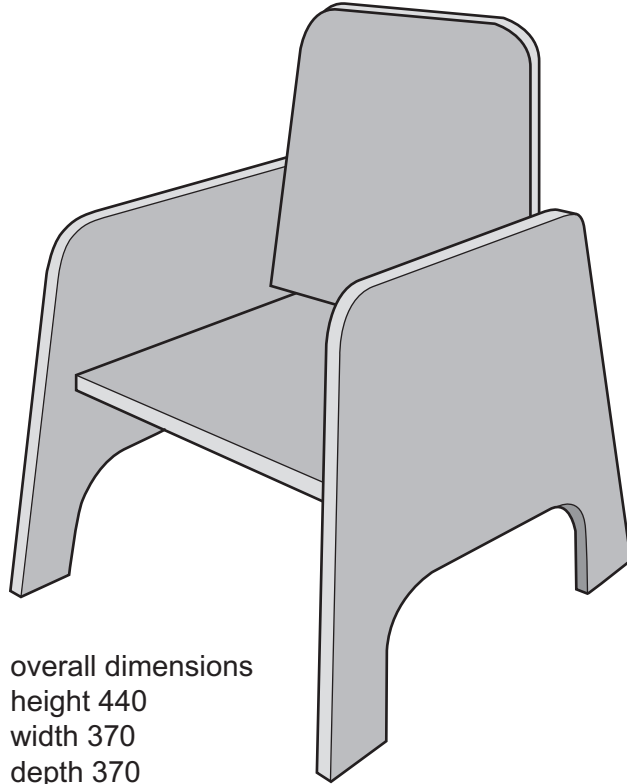

Fig. 12.1

- (a) Before designing the chair the student was invited to the nursery to discuss the design brief. State **three** questions that the student could have asked at the nursery before designing the chair.

1 .....

2 .....

3 .....

[3]

- (b) Give **two** examples where anthropometric data would need to be considered when designing the chair.

1 .....

2 .....

[2]

- (c) The prototype chair has been made from MDF.  
The final chair will be made from 15 mm thick beech veneered plywood.  
Give **two** advantages of making the prototype chair from MDF rather than 15 mm thick beech veneered plywood.

1 .....

2 .....

[2]

- (d) Fig. 12.2 shows an exploded view, showing five layers (plies) of 15 mm thick plywood.

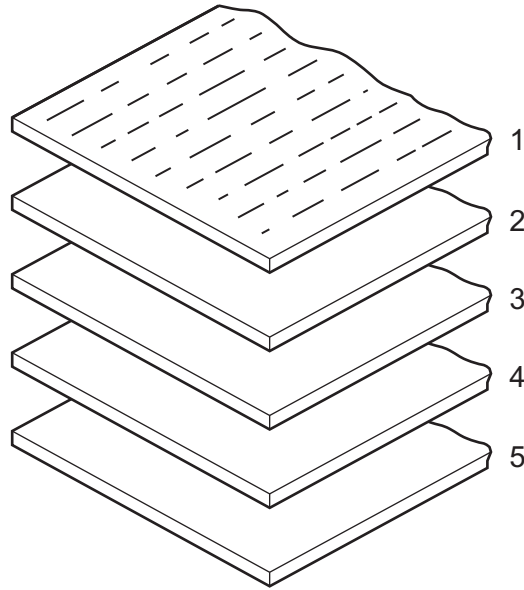

**Fig. 12.2**

- (i) Add sketches to Fig. 12.2 to show the grain direction on layers (plies) 2, 3, 4 and 5. [1]

- (ii) Give **one** advantage of using plywood rather than solid wood for the chair.

..... [1]

- (iii) Give **one** disadvantage of using plywood rather than solid wood for the chair.

..... [1]

- (e) Fig. 12.3 shows one of the dowel pegs used to join parts of the prototype chair.

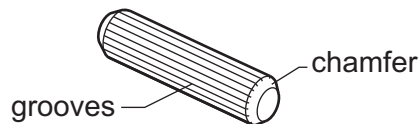

**Fig. 12.3**

- (i) State the purpose of the grooves.

..... [1]

- (ii) State the purpose of the chamfer.

..... [1]

(f) When the prototype chair was evaluated at the nursery, **three** improvements were recommended. Fig. 12.4 shows the positions for the improvements.

- 1 A hand hold is required at position **A** to make it easier to pick up and carry.
- 2 The dowel joint at **B** needs to be strengthened.
- 3 An attachment is required that could fit over **either** of the sides of the chair at positions **C** to hold a plastic cup.

The final design of chair will be made from 15 mm thick beech veneered plywood.

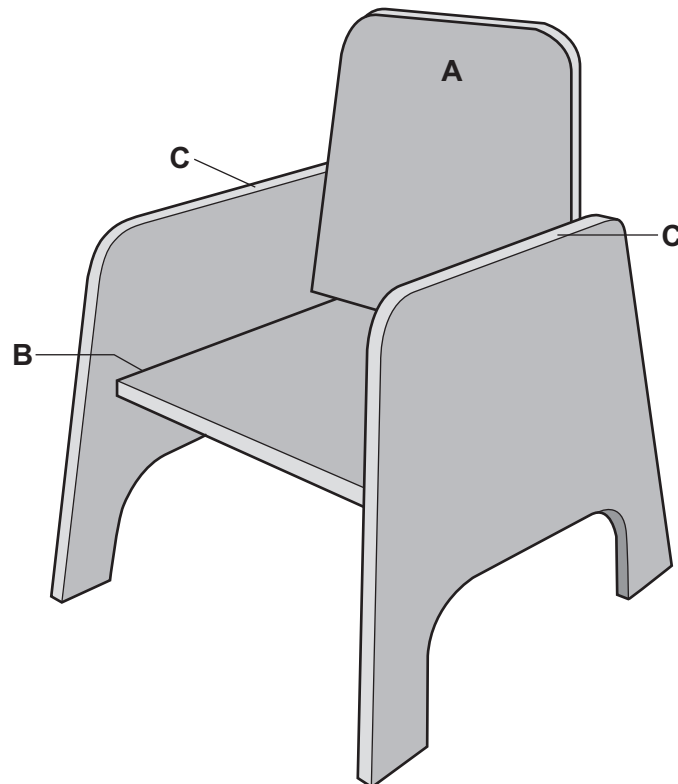

**Fig. 12.4**

- (i) Use sketches and notes to show how a hand hold could be produced at **A**. Name all the tools and equipment used.

- (ii) Use sketches and notes to show how a dowel joint, used to join the seat to the sides of the chair at **B**, could be strengthened. Name all materials and fittings used.

[4]

- (iii) Use sketches and notes to show a design for an attachment that could fit over either of the sides at positions **C** to hold the plastic cup shown in Fig. 12.5. The attachment must be removable. Name all materials and fittings used.

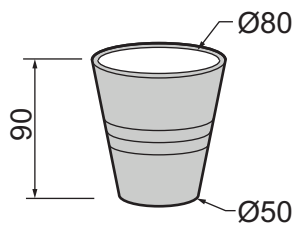

**Fig. 12.5**

[5]

13 Fig. 13.1 shows views of an adjustable table lamp made of acrylic.

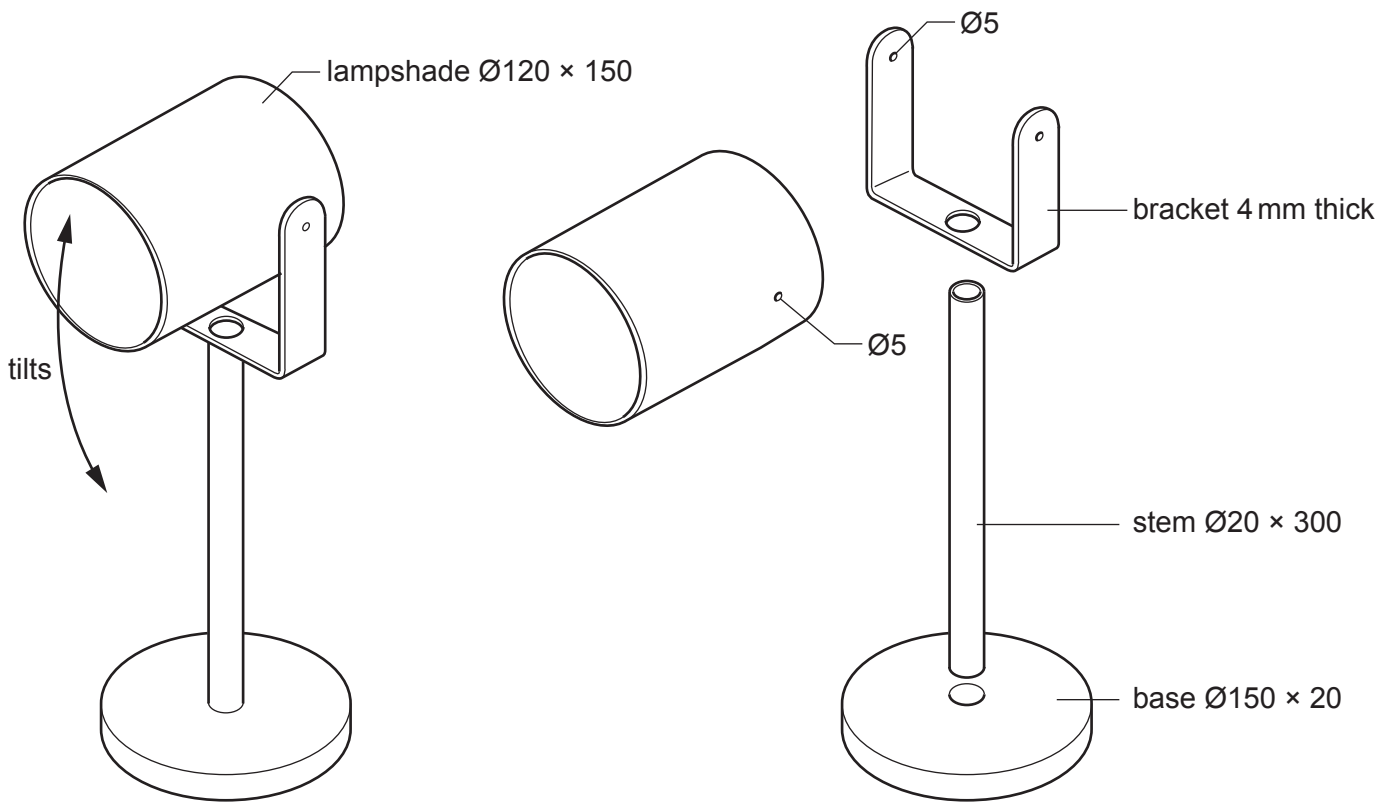

Fig. 13.1

(a) Fig. 13.2 shows the development (net) of the bracket.

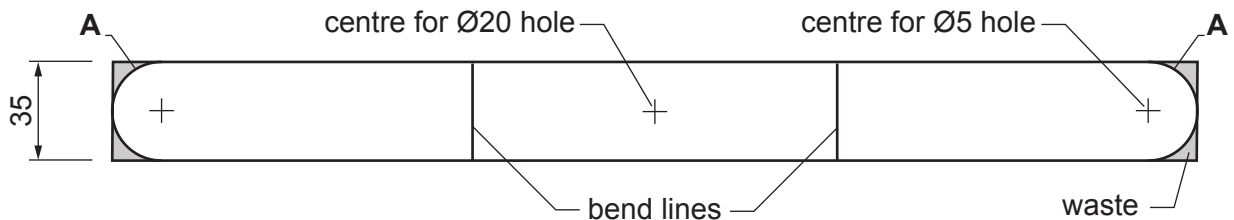

Fig. 13.2

(i) State **one** advantage of using a chinagraph pencil rather than a scribe to mark out the bend lines on the acrylic.

..... [1]

(ii) Name a suitable marking out tool that could be used to mark the arcs shown at **A** in Fig. 13.2.

..... [1]

(iii) Describe how the waste could be removed to produce an accurate semi-circular shape.

.....

..... [2]

- (b) When drilling holes in acrylic sheet there is a danger that the drill could 'snag', causing the acrylic to spin and crack.  
Use sketches and notes to show how the danger could be prevented.

[3]

- (c) Fig. 13.3 shows the development (net) ready to be bent to the shape of the bracket.  
The edges of the acrylic will be finished to a high quality before it is bent to shape.



Fig. 13.3

Name **two** tools, items of equipment or materials that could be used to produce a high quality finish on the edges of the acrylic.

1 .....

2 .....

[2]



- (d) (i) The lampshade is made of  $\text{Ø}120$  acrylic tube.  
Name a manufacturing process used to produce acrylic tube.

..... [1]

- (ii) The lampshade could be made by heating a sheet of acrylic and forming it to the shape of the lampshade. Fig. 13.4 shows a sheet of acrylic that could be formed to produce a lampshade with a diameter of approximately 120 mm.

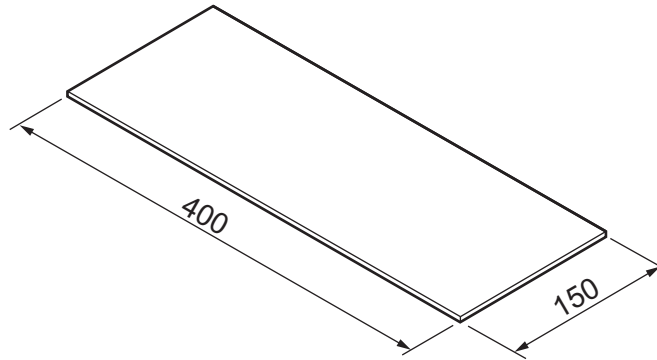
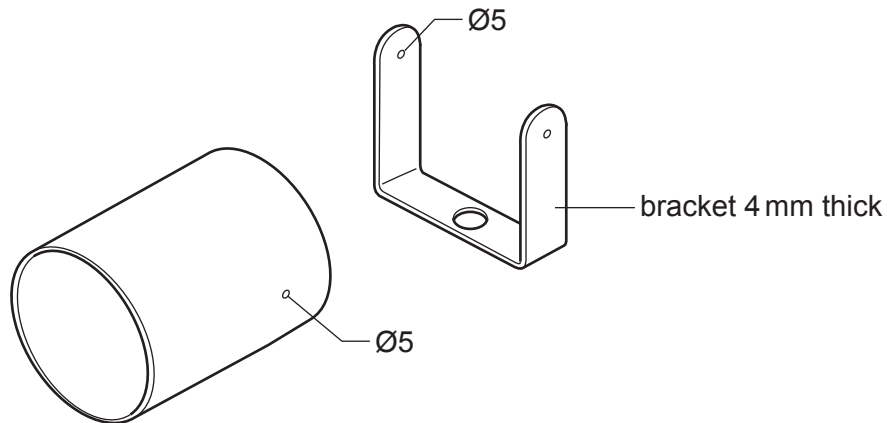

**Fig. 13.4**

Use sketches and notes to show how the sheet of acrylic could be heated and formed to produce the lampshade.  
Name all the items of equipment required to carry out the process.

[4]

- (e) Fig. 13.5 shows details of the lampshade and the bracket. The lampshade will be joined to the bracket by means of fittings that will go through the  $\text{Ø}5$  holes drilled in the lampshade and bracket.



**Fig. 13.5**

Use sketches and notes to show a suitable fitting that would allow the angle of the lampshade to be adjusted and locked in position by hand, without the aid of tools. Name the specific material from which the fittings are made.

[4]

- (f) The base of the table lamp is 20 mm thick.  
Use sketches and notes to show how a solid base  $\text{Ø}150 \times 20$  mm thick could be made using only 5 mm thick acrylic sheet.  
Include details of marking out, shaping and finishing to a high quality.

[4]

- (g) Fig. 13.6 shows the adjustable table lamp and part of the electrical cable. The electrical cable will be inserted into the top of the stem and then emerge through or under the base.

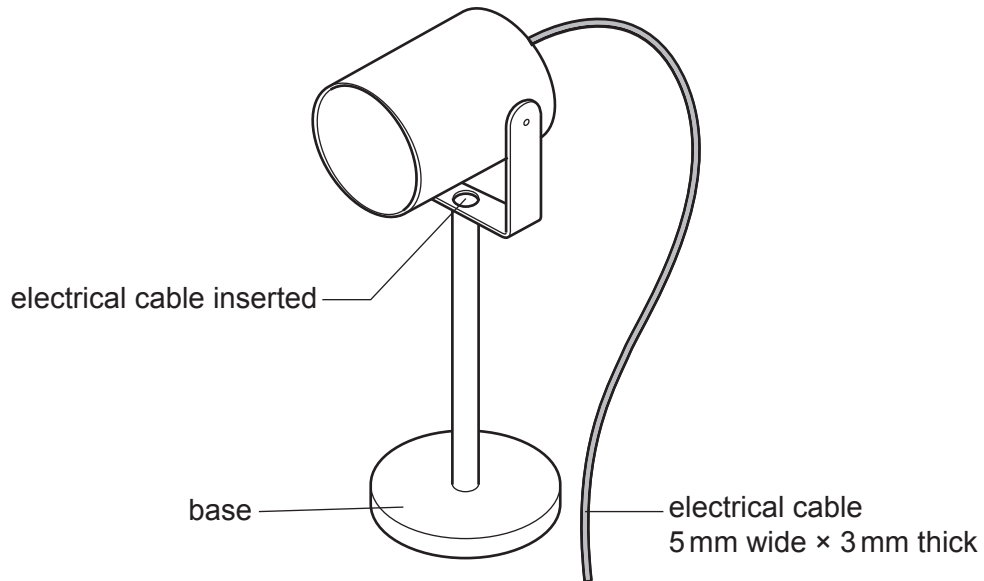

**Fig. 13.6**

Use sketches and notes to show how the electrical cable could be made to emerge through or under the base.

Include all constructional details.







**BLANK PAGE**

---

Permission to reproduce items where third-party owned material protected by copyright is included has been sought and cleared where possible. Every reasonable effort has been made by the publisher (UCLES) to trace copyright holders, but if any items requiring clearance have unwittingly been included, the publisher will be pleased to make amends at the earliest possible opportunity.

To avoid the issue of disclosure of answer-related information to candidates, all copyright acknowledgements are reproduced online in the Cambridge Assessment International Education Copyright Acknowledgements Booklet. This is produced for each series of examinations and is freely available to download at [www.cambridgeinternational.org](http://www.cambridgeinternational.org) after the live examination series.

Cambridge Assessment International Education is part of Cambridge Assessment. Cambridge Assessment is the brand name of the University of Cambridge Local Examinations Syndicate (UCLES), which is a department of the University of Cambridge.