

**Section A**

Answer **all** questions in this section.

**A1** A logo for a tool shop is shown below.

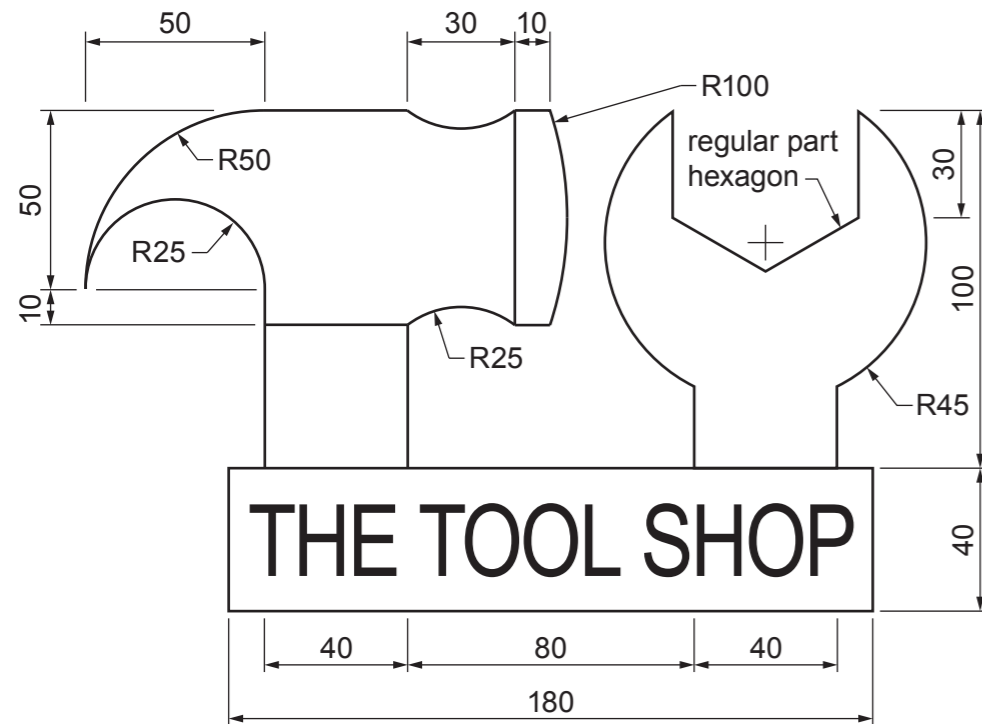

Complete the full size view of the tool shop logo in the space provided to the right by drawing:

- (a) the outer shape of the rectangle [2]
- (b) the claw hammer shape [7]
- (c) the spanner shape. [5]



**0979/52** May/June 2020 **1 hour**  
© UCLES 2020 DC (CE/CB) 198636

Centre Number ..... Candidate Number ..... Candidate Surname ..... Other Names ..... **[Turn over**

|                          |
|--------------------------|
| For<br>Examiner's<br>use |
|                          |
|                          |
|                          |
|                          |

**A2** A rotating open/closed sign for the shop is shown below.

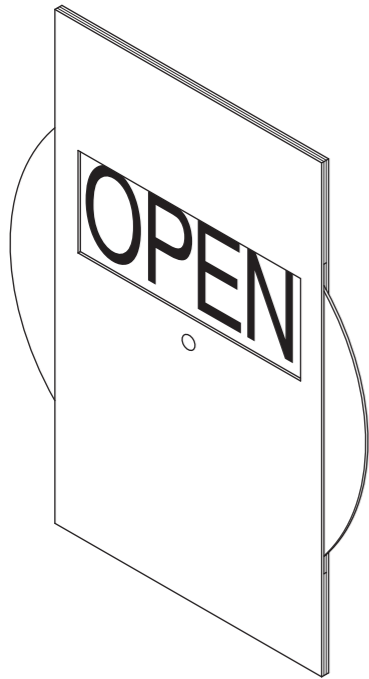

| Front piece    | Spacers    |
|----------------|------------|
|                |            |
| Rotating wheel | Back piece |
|                |            |

The sign is made from the five pieces of 1 mm cardboard shown in the table.

Complete the exploded view of the rotating shop sign by adding:

- (a) the rectangular hole in the front piece [2]
- (b) the rotating wheel [4]
- (c) the back piece. [2]

Ignore the thickness of the material.

**A3** A split pin is inserted through the centre of the sign to fasten the parts together and allow the wheel to rotate.

Complete the sectional view by adding the split pin.

[3]

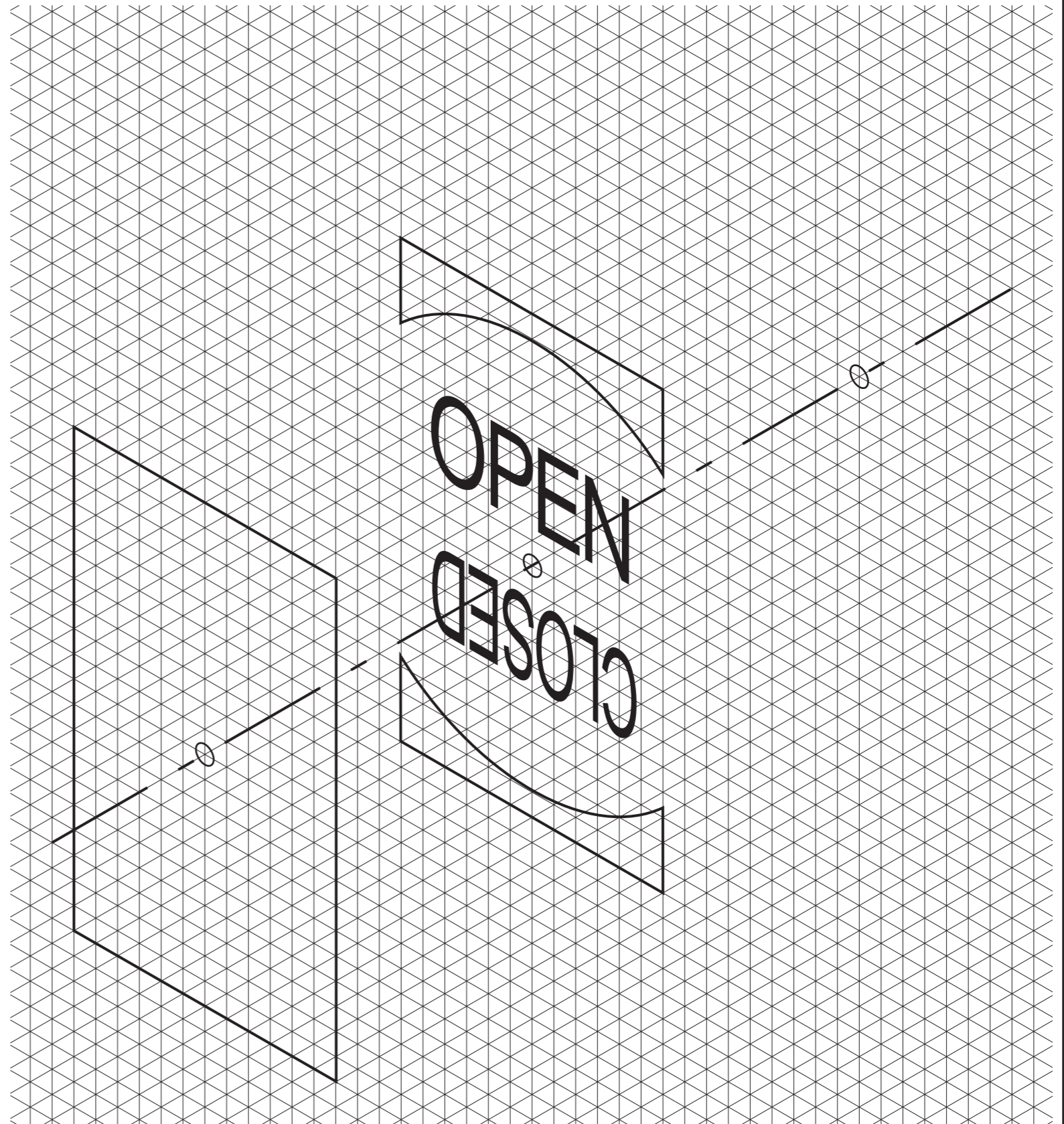
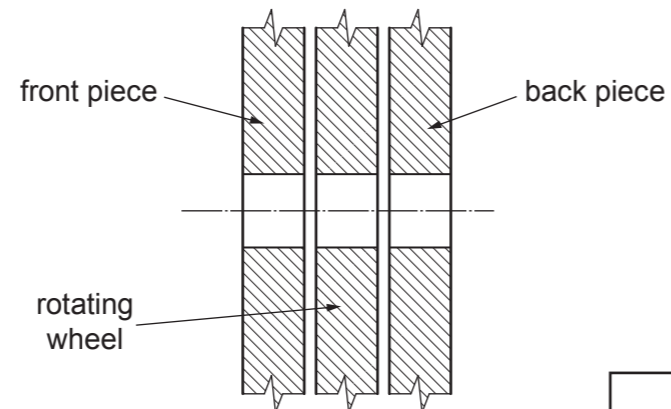

**Section B**  
Answer **either** question **B4** or **B5**.

**B4** Orthographic views of a tool rack are shown below.  
The tool rack is made from 10 mm thick softwood.

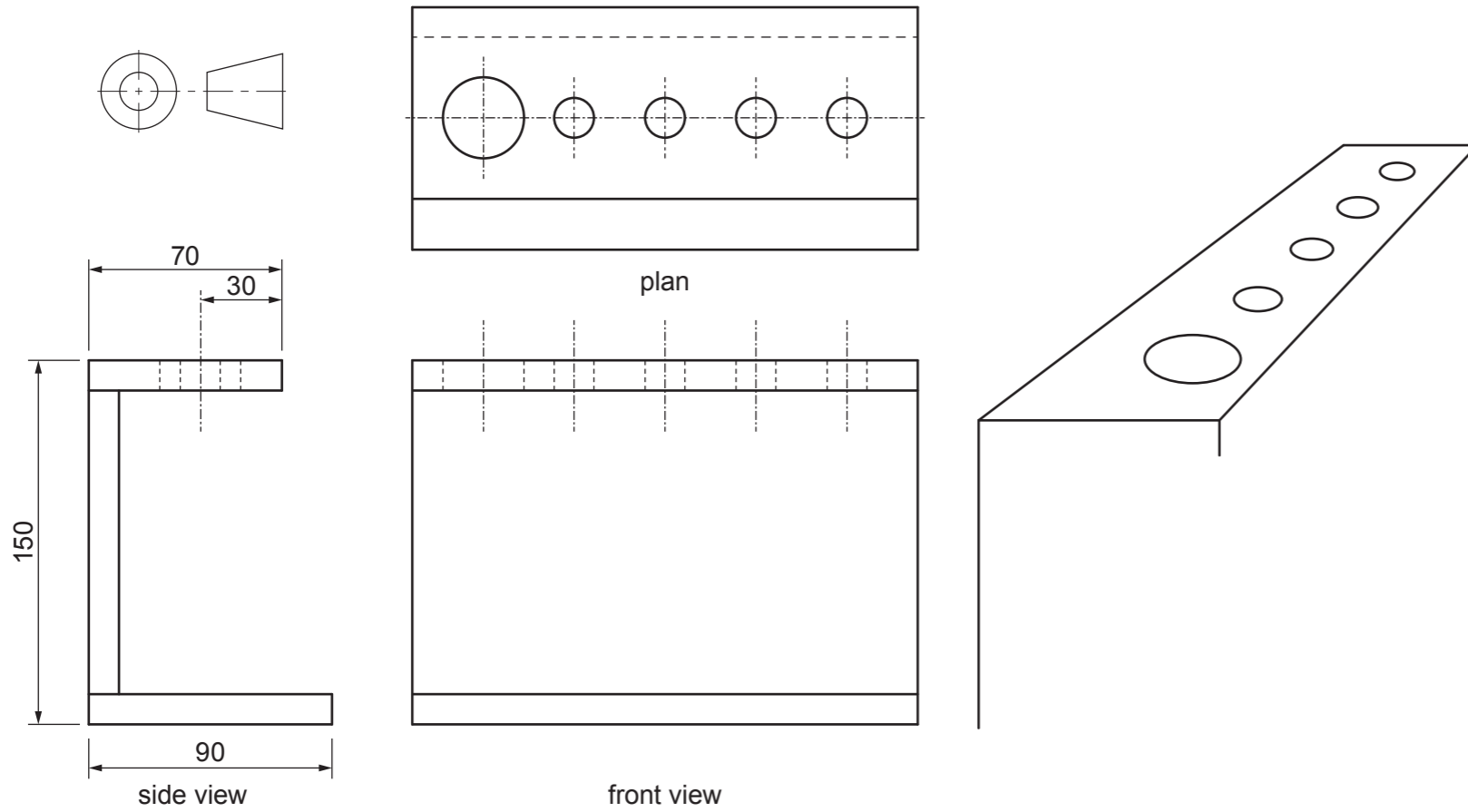

(a) Complete the single point perspective view of the tool rack to a scale of 1: 2. [13]

(c) The table below shows the sales of the most popular tools in a shop over one month.

| Tool        | Spanners | Screwdrivers | Hammers | Pliers |
|-------------|----------|--------------|---------|--------|
| Number Sold | 42       | 53           | 15      | 37     |

In the space to the right draw a bar chart to show the sales of each tool. [5]

VP

(b) Orthographic views of a socket spanner are shown below.

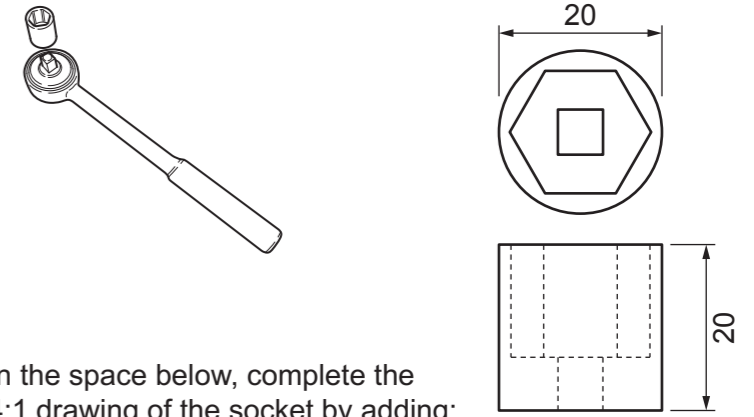

In the space below, complete the 4:1 drawing of the socket by adding:

- (i) the right-hand half of the hexagon [1]
- (ii) the sides of the socket spanner [1]
- (iii) the top ellipse. [5]

Ignore hidden detail.

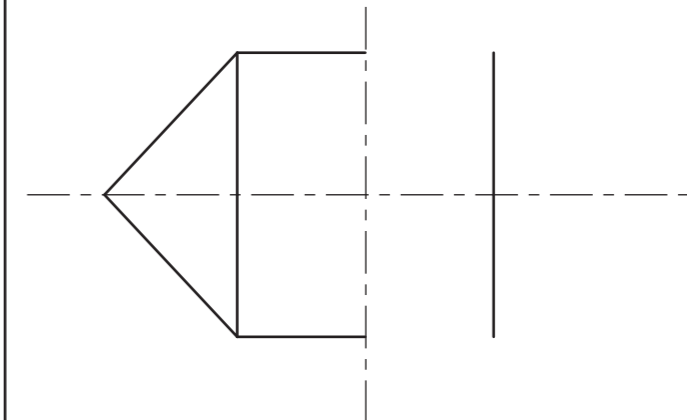

|                          |
|--------------------------|
| For<br>Examiner's<br>use |
|                          |
|                          |
|                          |
|                          |

**B5** Orthographic views of a blister pack for screws are shown below.

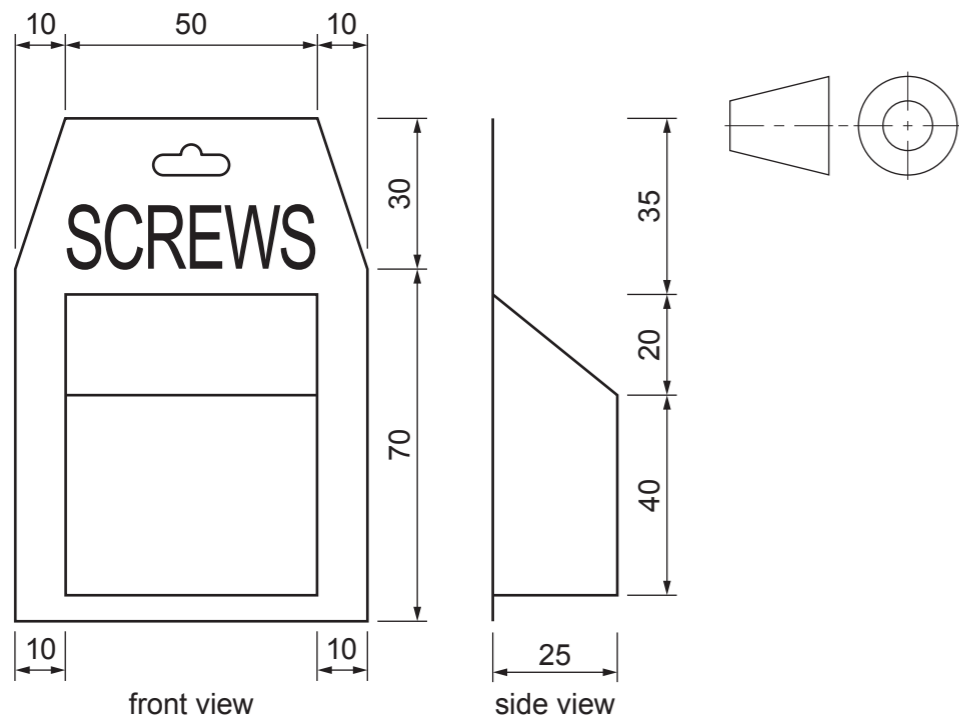

(a) Complete the full size isometric view of the blister pack below. [12]

  
**SCREWS**

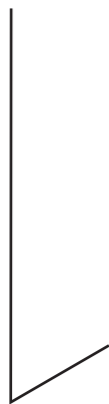

(b) The mould for vacuum forming the blister is shown to the right.

Add sketches and notes to show:

- (i) **two** different modifications to the mould that would make it easier to remove from the blister after vacuum forming [4]
- (ii) a modification to the mould that would help prevent air pockets and ensure the blister has good definition and shape. [2]

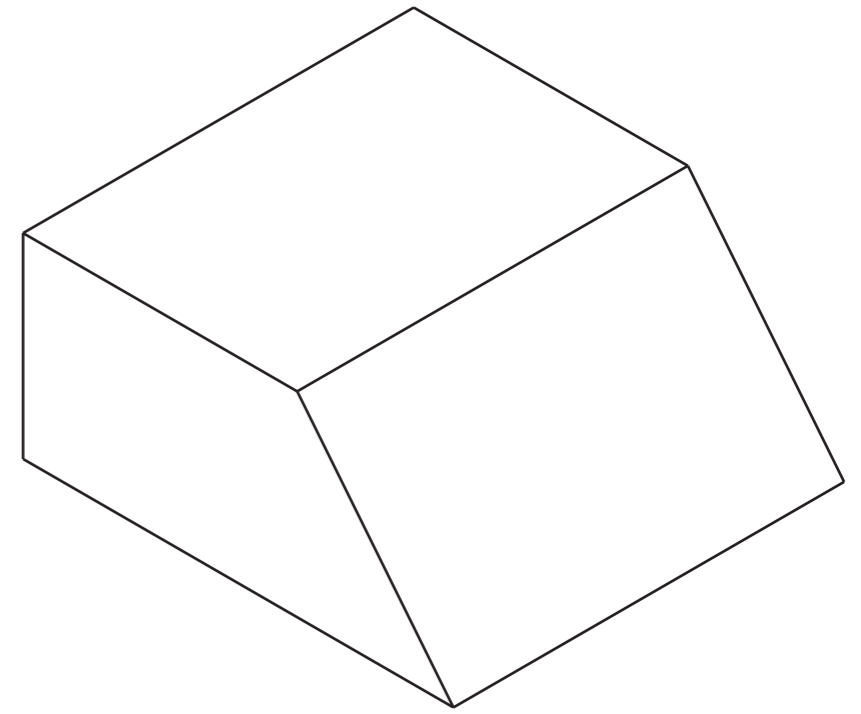

(c) The blisters are to be vacuum formed in thin clear plastic, before being trimmed to size and glued to the backboard.

Complete the table below to show **one** safety precaution for each stage in the making process.

| Process  | Safety precaution       |
|--|-------------------------|
| Vacuum forming the plastic blister.                                | .....<br>.....<br>..... |
| Trimming the plastic blister to size with a craft knife.           | .....<br>.....<br>..... |
| Gluing the plastic blister to the backboard with contact adhesive. | .....<br>.....<br>..... |

[3]

(d) The blister packs are to be mass produced in quantities of 5000.

State **one** suitable commercial process that could be used to:

- (i) cut out the card backboards  
..... [1]
- (ii) print the SCREWS lettering onto the backboards.  
..... [1]

(e) The symbol below is to be printed onto the blister pack.

Explain **one** benefit of using symbols on products instead of written instructions.



.....  
.....  
..... [2]