



Cambridge International Examinations
Cambridge International General Certificate of Secondary Education

CANDIDATE
NAME

--

CENTRE
NUMBER

--	--	--	--	--

CANDIDATE
NUMBER

--	--	--	--

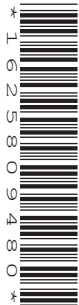

CO-ORDINATED SCIENCES

0654/32

Paper 3 (Core)

October/November 2017

2 hours

Candidates answer on the Question Paper.

No Additional Materials are required.

READ THESE INSTRUCTIONS FIRST

Write your Centre number, candidate number and name on all the work you hand in.

Write in dark blue or black pen.

You may use an HB pencil for any diagrams or graphs.

Do not use staples, paper clips, glue or correction fluid.

DO NOT WRITE IN ANY BARCODES.

Answer **all** questions.

Electronic calculators may be used.

You may lose marks if you do not show your working or if you do not use appropriate units.

A copy of the Periodic Table is printed on page 32.

At the end of the examination, fasten all your work securely together.

The number of marks is given in brackets [] at the end of each question or part question.

This document consists of **32** printed pages.

1 Fig. 1.1 shows a diagram of the female reproductive system.

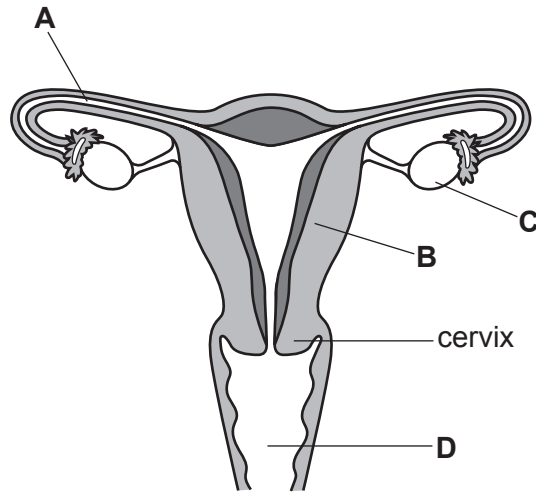

Fig. 1.1

(a) (i) State the letter which represents where the following processes occur.

ovulation

fertilisation

receives penis during sexual intercourse

[3]

(ii) State the function of the uterus.

.....[1]

(b) (i) Describe the process of fertilisation.

.....

[2]

(ii) Name the cell produced by fertilisation.

.....[1]

(c) Human offspring are produced by sexual reproduction.

State **two** ways in which sexual reproduction differs from asexual reproduction.

1

.....

2

.....

[2]

- 2 (a) Complete the sentences about atomic structure using words chosen from the list.

Each word may be used once, more than once or not at all.

negative

neutral

neutrons

nucleus

positive

protons

In the middle of an atom is a that contains
..... and

Atoms also contain electrons that have a electric charge.

When electrons are removed from an atom, an ion with a charge is
formed. [3]

- (b) The Periodic Table includes the four metals listed.

copper, Cu

lithium, Li

potassium, K

sodium, Na

- (i) Using the Periodic Table on page 32, state which of these metals

are in the same group of the Periodic Table,

..... and and

are in the same period of the Periodic Table.

..... and

[2]

- (ii) Place the four metals in decreasing order of reactivity.

..... (most reactive)

.....

.....

..... (least reactive)

[1]

(iii) Fig. 2.1 shows lithium reacting with water.

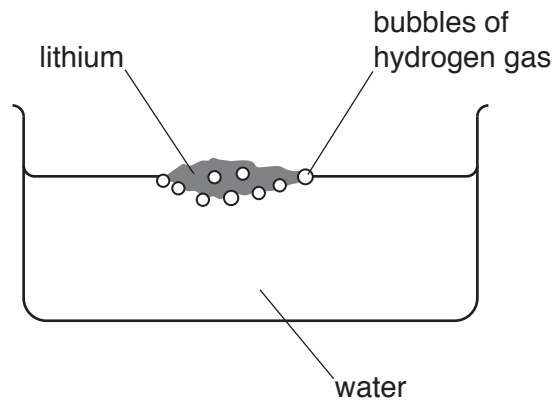

Fig. 2.1

Describe the test for hydrogen gas.

test

result

[2]

(c) Argon and chlorine are gaseous non-metallic elements.

Predict and explain the change in appearance, if any, when these gases are bubbled through colourless sodium bromide solution, as shown in Fig. 2.2.

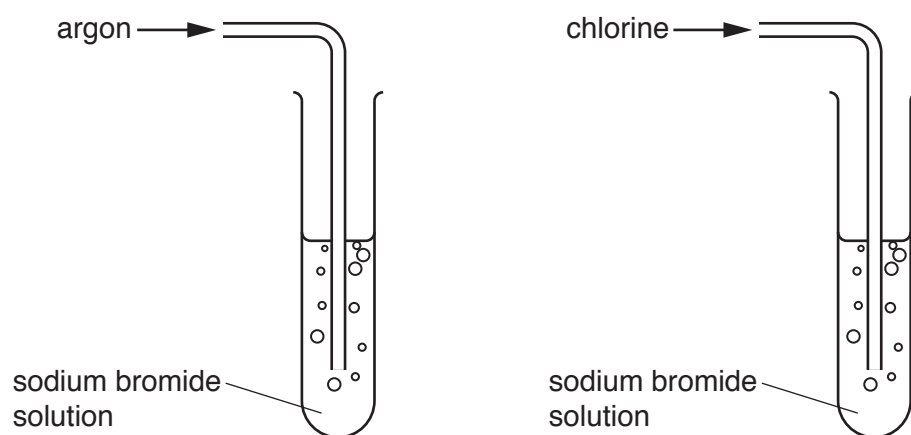

Fig. 2.2

argon

change

explanation

.....

chlorine

change

explanation

.....

[3]

- 3 (a) Fig. 3.1 shows a student reading a book.

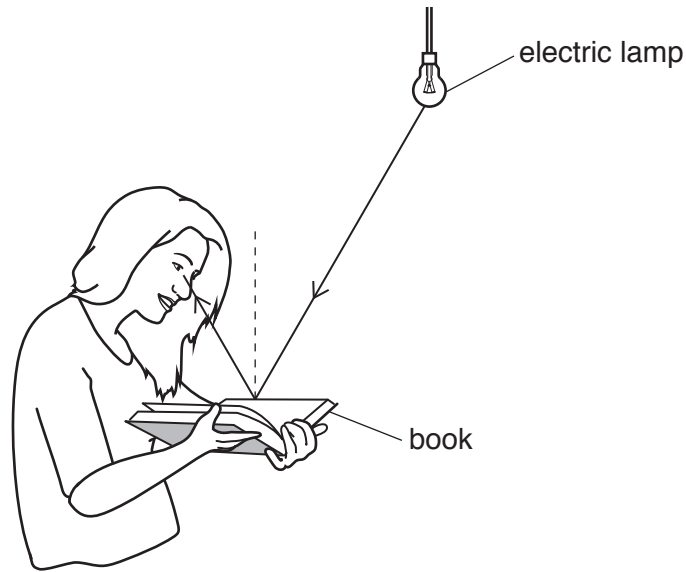

Fig. 3.1

Light from an electric lamp is reflected by the book into the student's eyes.

- (i) On Fig. 3.1, label the angle of incidence with the letter i . [1]
- (ii) The angle of reflection is 30° . State the angle of incidence.

Explain your answer.

angle of incidence

explanation

.....

[2]

- (iii) State the useful energy transfer that happens in the electric lamp.

from energy to energy [1]

(b) The student watches her teacher set up a radiation detector in the school science laboratory.

A sealed radioactive source, strontium-90, is placed on the bench next to the radiation detector.

Strontium-90 emits β -particles. A small count rate is measured.

(i) Suggest a suitable radiation detector for this experiment.

.....[1]

(ii) State the name of the particle, found in an atom, that is identical to a β -particle.

.....[1]

(iii) When the teacher repeats the experiment a few minutes later, the count rate measured is slightly higher.

Suggest **one** reason for this.

.....

.....[1]

(iv) When not in use, the strontium-90 source is stored in a box lined with lead.

Explain why this is done.

.....

.....[1]

(c) The teacher asks the student to test one of the springs from a chair. Fig. 3.2 shows the chair.

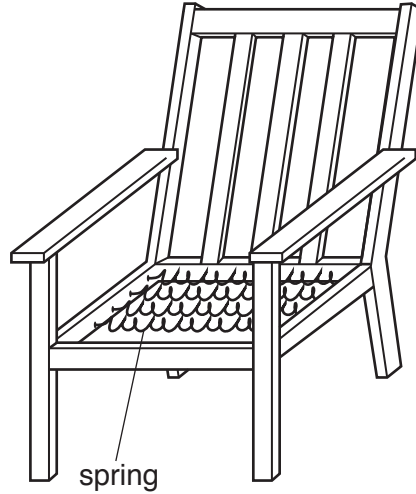

Fig. 3.2

The student measures the extension of the spring for different stretching forces. She plots the graph shown in Fig. 3.3.

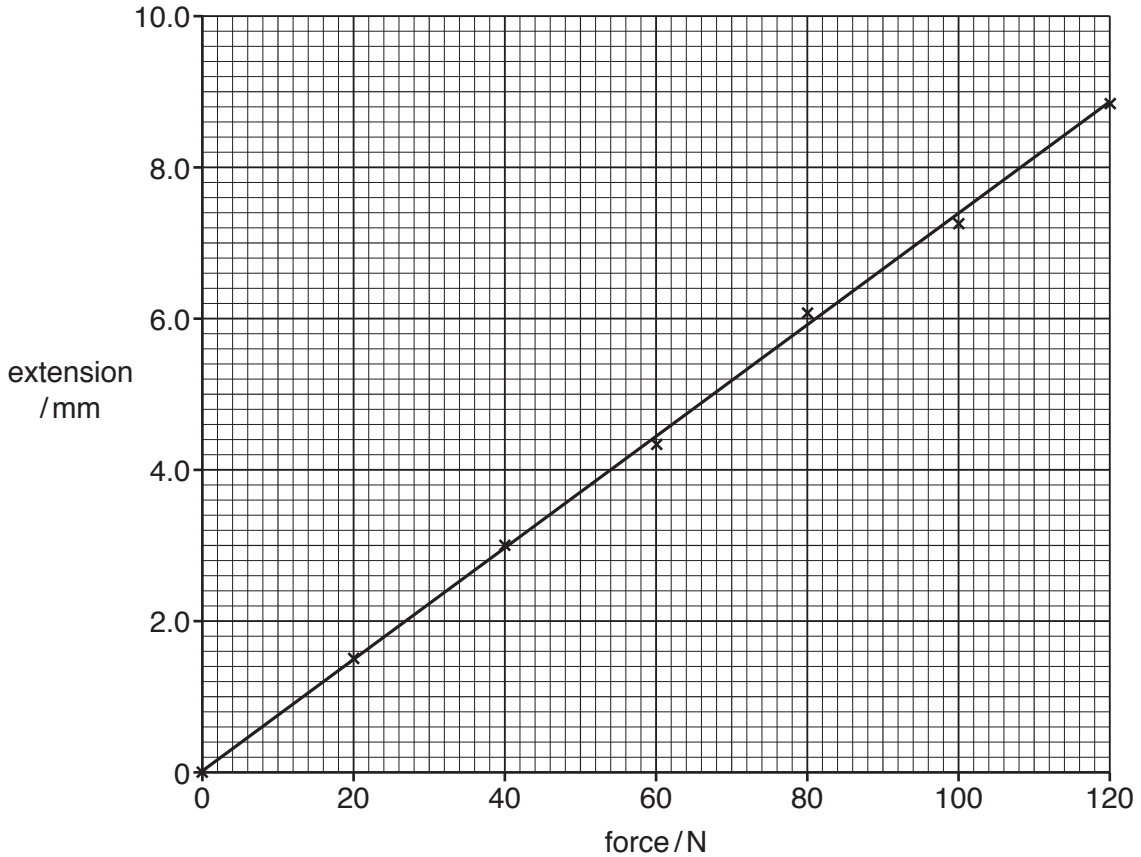

Fig. 3.3

(i) Use the graph to state the force needed to give an extension of 4.0 mm.

..... N

[1]

(ii) The force changes the shape of the spring.

State **one other** effect that a force can have on a body.

.....[1]

4 Food chains show the flow of energy from one organism to another.

The following paragraph is a description of some of the organisms in a desert environment and what they feed on.

The top predator is a hawk. The hawk eats snakes, which eat desert mice. The desert mice feed on plants such as thorn acacias.

(a) (i) Using the information in the paragraph, draw a food chain using all of the organisms.

[2]

(ii) Name the producer in this food chain.

.....[1]

(iii) Name the herbivore in this food chain.

.....[1]

(b) State the principal source of energy for all food chains.

.....[1]

(c) Organisms such as hawks have evolved to have good eyesight. This is an example of natural selection.

Define the term *natural selection*.

.....

.....

.....[2]

- 5 Ionic compounds contain ions.
Covalent compounds are made of molecules.
Mixtures contain two or more compounds or elements.

(a) (i) Complete Table 5.1 by writing a tick (✓) in the column that describes each substance.

Table 5.1

substance	element	ionic compound	covalent compound	mixture
air				
bromine				
carbon dioxide				
iron oxide				

[3]

(ii) Glucose has the chemical formula $C_6H_{12}O_6$.

Describe what this chemical formula shows about the elements in one molecule of glucose.

.....

[2]

(b) Fig. 5.1 shows processes, P and Q, that are used to extract metallic elements from metal compounds.

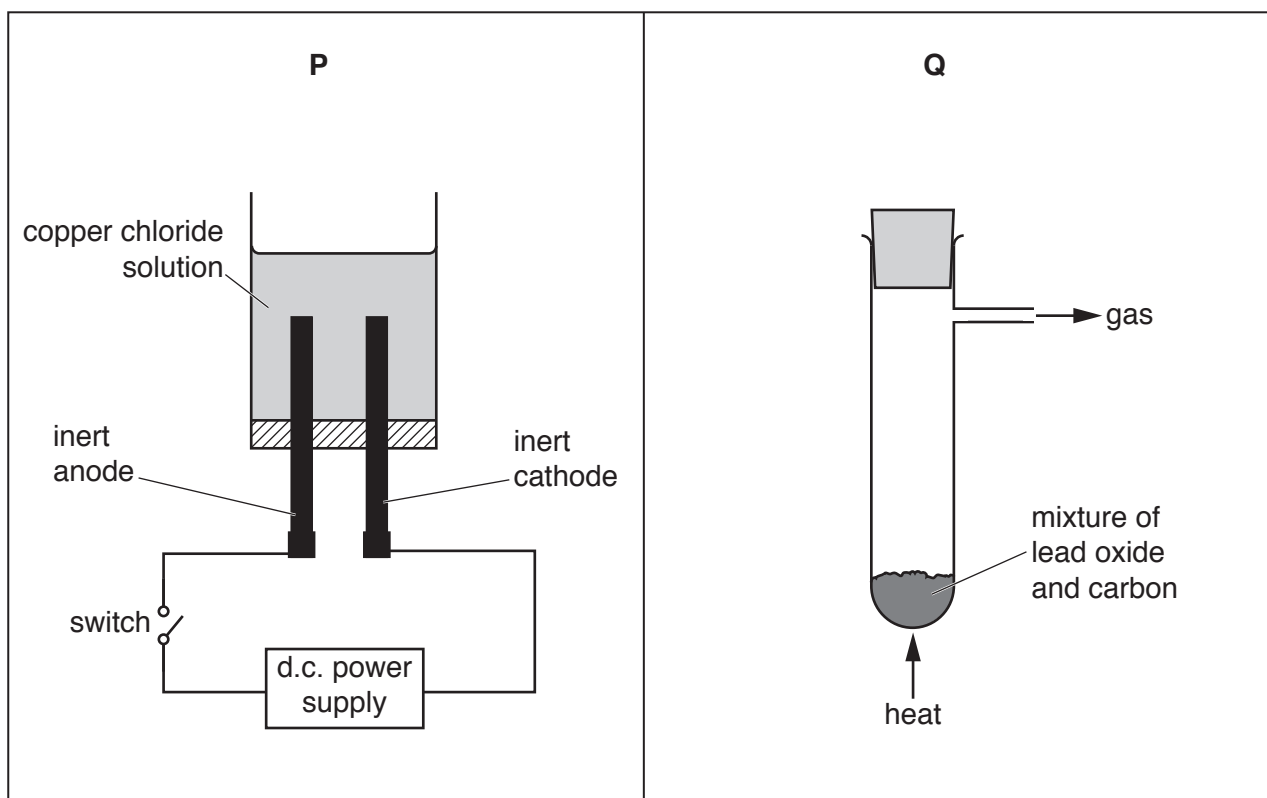

Fig. 5.1

(i) Name process **P**.

.....[1]

(ii) Describe what is **observed** at the anode and at the cathode in process **P** when the switch in Fig. 5.1 is closed.

at the anode

at the cathode

[2]

(iii) In process **Q**, a redox reaction occurs that produces lead and a gas.

Complete the **word** equation for the reaction that occurs in process **Q**.

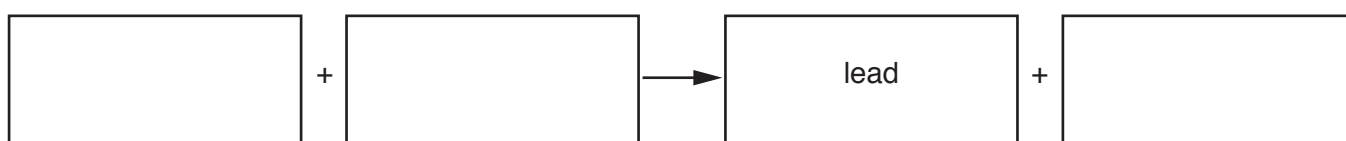

[2]

(iv) State and explain which of the reacting substances is reduced during the reaction in process **Q**.

substance

explanation

.....

[1]

6 (a) A microwave oven contains a motor which produces a quiet sound with a high pitch.

(i) State whether the sound waves produced have a large or small amplitude.

Explain your answer.

the amplitude is

because

.....

[1]

(ii) State whether the sound waves produced have a high or low frequency.

Explain your answer.

the frequency is

because

.....

[1]

(b) Some water is heated in the microwave oven for five minutes.

Fig. 6.1 shows how the temperature of the water changes with time.

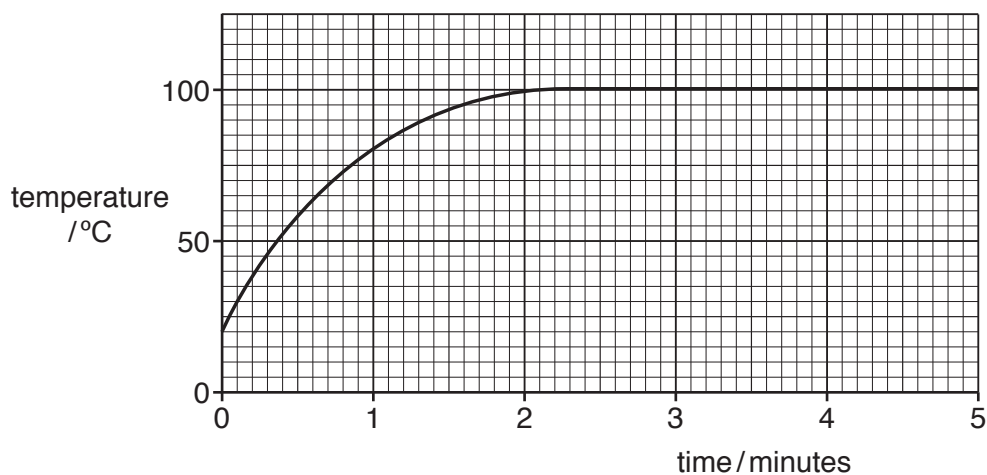

Fig. 6.1

(i) On the graph, mark with the letter **B** a point when the water is boiling.

Explain your answer.

.....

.....

[2]

(ii) State what is meant by the term *boiling point*.

.....
[1]

(iii) When the liquid water boils, it turns into steam. Steam is a gas.

Fig. 6.2 shows the arrangement of particles in a solid, a liquid and a gas.

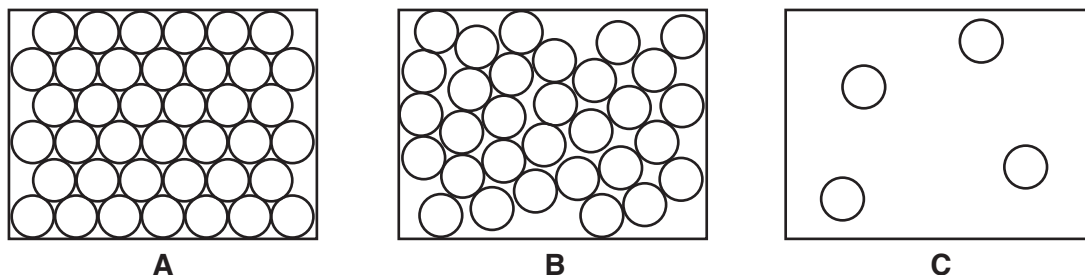

Fig. 6.2

Use ideas about the arrangement and spacing of particles to state **and** explain which diagrams, **A**, **B** or **C**, best describe water and steam.

Explain your answer.

water

explanation

steam

explanation

[2]

(c) Fig. 6.3 shows the mains electrical cable of the microwave oven.

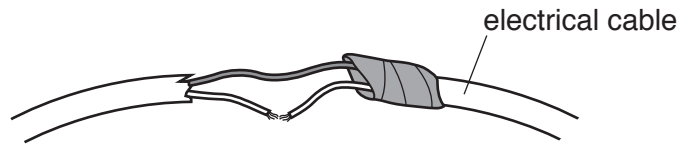

Fig. 6.3

State **one** electrical hazard that is visible in Fig. 6.3.

Explain why using the microwave oven could be dangerous.

hazard

explanation

.....

[2]

(d) The microwave oven uses microwaves.

Microwaves are part of the electromagnetic spectrum.

Fig. 6.4 shows an inaccurate electromagnetic spectrum drawn by a student.

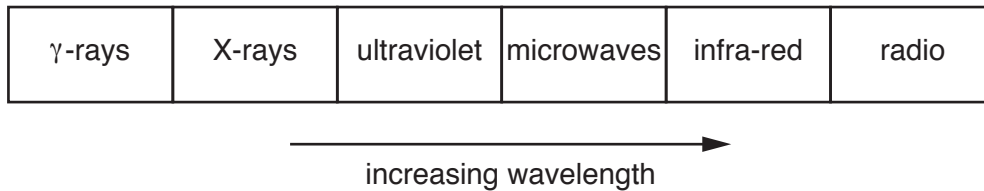

Fig. 6.4

State **two** errors shown in Fig. 6.4.

1

.....

2

.....

[2]

Please turn over for Question 7.

7 Fig. 7.1 is a diagram of the different types of teeth in a human.

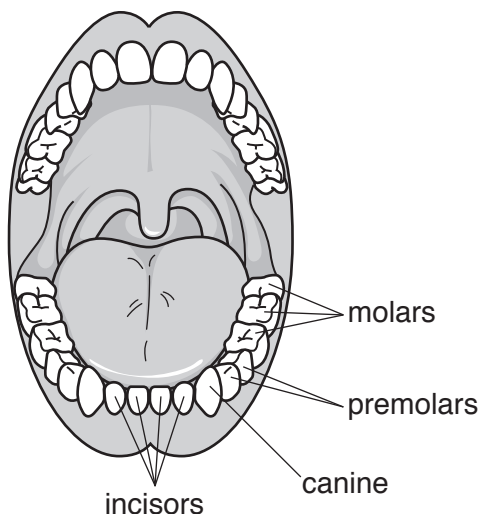

Fig. 7.1

(a) (i) Draw one line from each type of tooth to its correct function.

type of tooth	function
canine	biting and cutting
incisor	grinding and chewing
molar	piercing and tearing

[2]

(ii) Describe how the structure of a molar differs from a canine.

.....
[1]

(b) Tooth decay occurs when the enamel of the tooth gets worn away.

Name the type of organism that causes tooth decay.

.....[1]

(c) Fluoride strengthens tooth enamel making it more resistant to tooth decay.

Some countries add fluoride to drinking water.

(i) Suggest **one** possible disadvantage of adding fluoride to drinking water.

.....[1]

(ii) State **two other** ways to avoid tooth decay.

1

2 [2]

8 Water is a neutral liquid.

(a) (i) State the pH of pure water.

.....[1]

(ii) Complete the general equation for neutralisation of an acid by an alkali.

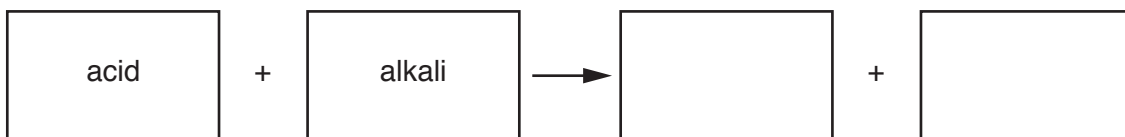

[2]

(iii) Explain the use of lime (calcium oxide) in the treatment of soil.

.....

[2]

(b) Sulfur dioxide, SO₂, is a gas that is released into the air by human activity as well as natural processes.

(i) Describe how sulfur dioxide is released into the air by

human activity,

.....

a natural process.

.....

[2]

(ii) State **one** way that sulfur dioxide in the atmosphere damages the environment.

.....

.....[1]

9 (a) A boy rides his bicycle along a straight level road.

Fig. 9.1 shows a distance-time graph for his ride.

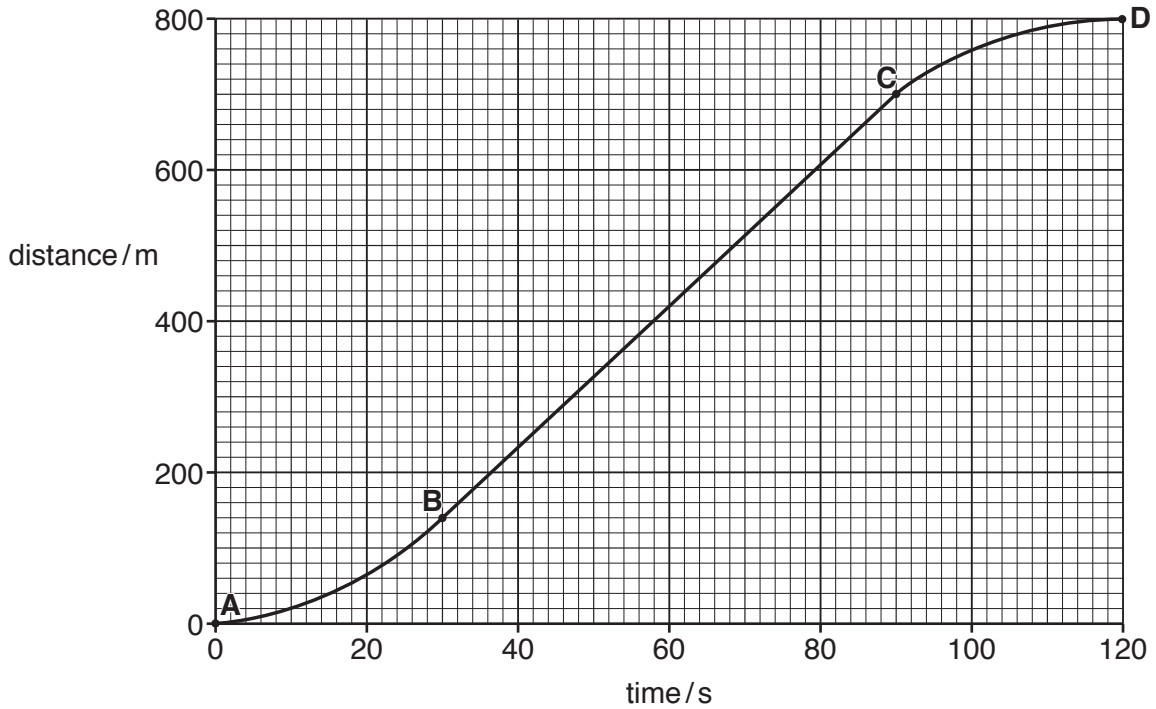

Fig. 9.1

(i) Describe the motion of the bicycle between **A** and **B**.

.....[1]

(ii) Calculate the speed of the bicycle between **B** and **C**.

Show your working.

speed = m/s [2]

(iii) State the main energy transfer that takes place as the bicycle slows down and stops.

from energy to energy [1]

(b) The bicycle frame is made from a block of aluminium of mass 7.5 kg.

The dimensions of the block of aluminium are shown in Fig. 9.2.

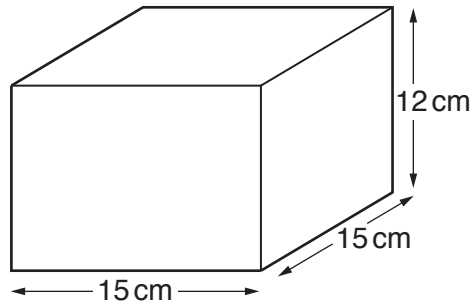

Fig. 9.2

Calculate the density of this block of aluminium in g/cm^3 .

State the formula you use and show your working.

formula

working

density = g/cm^3 [3]

(c) Fig. 9.3 shows a car behind a bicycle at night.

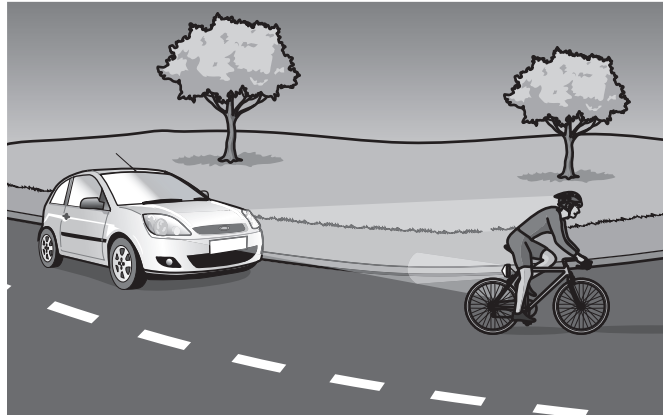

Fig. 9.3

A reflector on the back of the bicycle is made from many small red plastic prisms, one of which is shown in Fig. 9.4.

A ray of light from the headlamp of the car enters the prism.

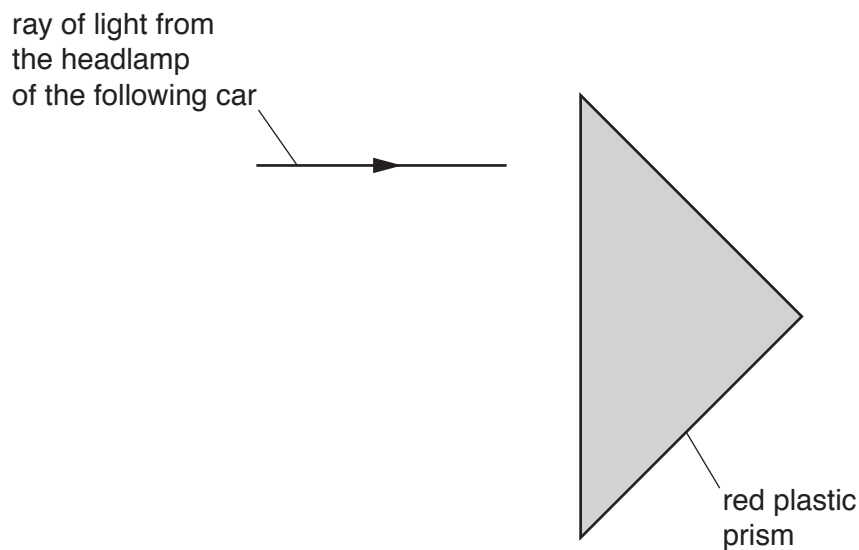

Fig. 9.4

Total internal reflection occurs within the prism.

On Fig. 9.4, complete the path taken by the ray of light until it emerges from the prism. [2]

(d) The bicycle has a front lamp, **A**, and a rear lamp, **B**, powered by the same battery.

Fig. 9.5 shows how the lamps are connected.

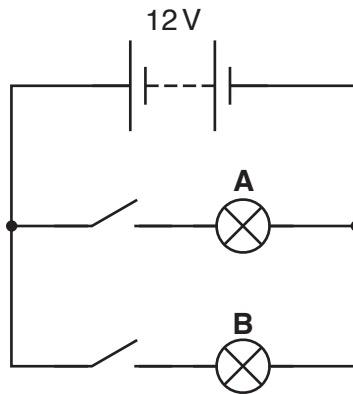

Fig. 9.5

(i) State the name given to this arrangement of lamps in a circuit.

.....[1]

(ii) Lamp **A** has a resistance of $5.0\ \Omega$.

The battery has a voltage of 12V.

Calculate the current flowing through lamp **A** when the switch is closed.

State the formula you use and show your working.

formula

working

current A [2]

10 Fig. 10.1 shows a photograph of a germinating pea seed.



Fig. 10.1

(a) Name the response shown by the root in Fig. 10.1.

.....[1]

(b) (i) Oxygen is one of the conditions required for germination.

Explain why germinating seeds require oxygen.

.....[1]

(ii) State **two other** conditions required for germination.

1

2

[2]

(c) (i) After planting, germinating seeds do **not** photosynthesise immediately.

Suggest **one** reason for this.

.....[1]

(ii) State the **word** equation for photosynthesis.

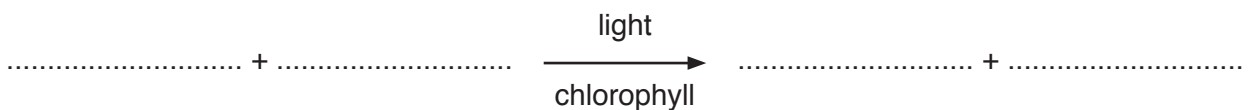

[2]

(d) Plants also need mineral ions for healthy growth.

State the mineral ion required for chlorophyll production.

.....[1]

11 (a) Fig. 11.1 shows the structure of a molecule of an alkane.

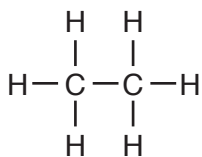

Fig. 11.1

(i) Name this alkane.

.....[1]

(ii) Complete Fig. 11.2 to show the structure of a molecule of the **alkene** that contains only two carbon atoms.

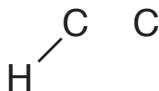

Fig. 11.2

[2]

(b) Fig. 11.3 shows clay pots being heated strongly in a kiln.

The hydrocarbon propane, C_3H_8 , is supplied to the gas burner.

Hot gases circulate through the kiln, heating the clay pots and then leaving through the top of the kiln.

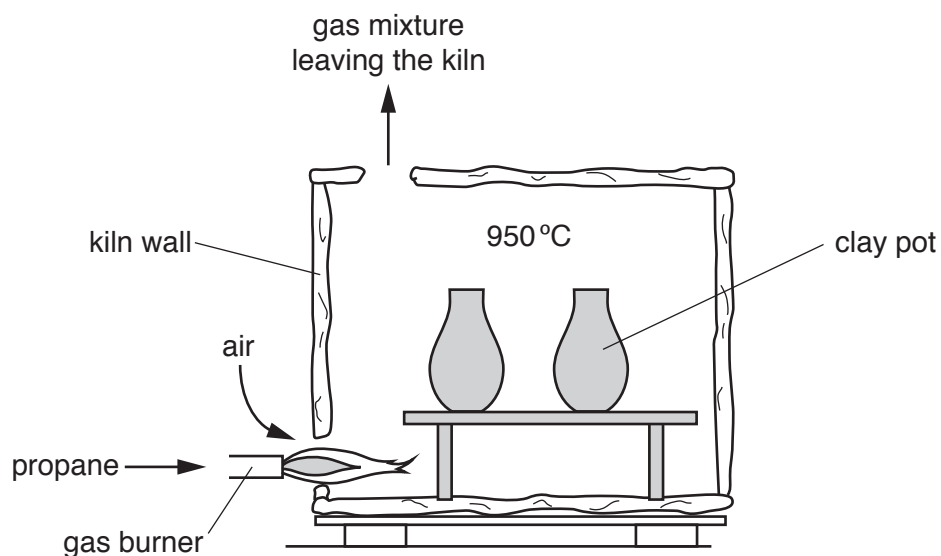

Fig. 11.3

(i) Explain why the gas mixture leaving the kiln contains large amounts of carbon dioxide and water vapour.

.....
[1]

(ii) Explain why the gas mixture leaving the kiln contains nitrogen and argon.

.....

[2]

- (c) Sometimes clay pots are covered with a glaze before they go into the kiln.

Glaze is a mixture of solid compounds that melt at high temperatures. It forms a coloured, shiny layer on the pots as they cool.

Four compounds found in a glaze are shown.

calcium carbonate, CaCO_3

cobalt oxide, CoO

copper oxide, CuO

silicon dioxide, SiO_2

- (i) One of these compounds undergoes thermal decomposition in the kiln.

State which compound decomposes and name **one** of the products of the decomposition.

compound

product

[2]

- (ii) Predict which **two** compounds produce colours in the glaze layer.

Explain your answer.

compounds and

explanation

.....

[2]

Please turn over for Question 12.

- 12 (a) A man drives a car. When he gets out of the car he touches the door handle while his feet are on the ground. He experiences an electric shock.

Suggest why this happens.

.....

.....

.....

..... [2]

- (b) A relay is needed in many electrical circuits in a car.

Fig. 12.1 shows a simple relay circuit.

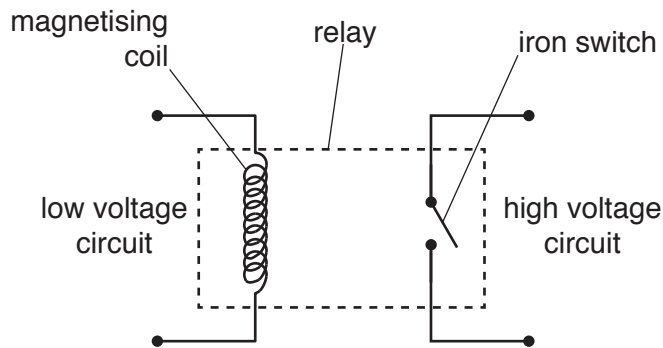

Fig. 12.1

Use words or phrases from the list to complete the sentences to describe the action of a relay.

You may use each word or phrase once, more than once or not at all.

- an electric a magnetic coil high iron switch low**

Electricity passes through the voltage circuit.

This causes field to be produced around the coil.

The is closed by this field and completes the

..... voltage circuit. [2]

- (c) The gasoline (petrol) used in the car is produced from petroleum.

Petroleum is a non-renewable energy source.

Name **one other** non-renewable energy source and **one** renewable energy source.

non-renewable energy source

renewable energy source

[2]

(d) Car wheels are usually made from steel. Some cars have aluminium alloy wheels.

Suggest a simple way to show that a wheel is **not** made from steel.

Explain your answer.

.....
.....[1]

13 Table 13.1 shows the population of mountain gorillas in the Democratic Republic of Congo between 1960 and 2007.

Table 13.1

year	population
1960	450
1978	260
1981	250
1989	320
2003	380
2007	380

(a) Calculate the difference in population between 1960 and 2007.

.....[1]

(b) (i) Loss of habitat caused by deforestation is one of the reasons for the decrease in population between 1960 and 1981.

Suggest **two** other reasons for the declining population between 1960 and 1981.

1

2

[2]

(ii) Deforestation causes loss of habitat.

List **two** other undesirable effects of deforestation.

1

2

[2]

(c) The population of mountain gorillas has been increasing from 1981.

Suggest **two** steps the government may have taken to conserve the gorilla population.

1

2

[2]

(d) It is important that species and their habitats are conserved.

State **two** other natural resources that should be conserved.

1

2

[2]

The Periodic Table of Elements

Group																	
I	II											III	IV	V	VI	VII	VIII
3 Li lithium 7	4 Be beryllium 9	Key atomic number atomic symbol name relative atomic mass										5 B boron 11	6 C carbon 12	7 N nitrogen 14	8 O oxygen 16	9 F fluorine 19	10 Ne neon 20
11 Na sodium 23	12 Mg magnesium 24											13 Al aluminium 27	14 Si silicon 28	15 P phosphorus 31	16 S sulfur 32	17 Cl chlorine 35.5	18 Ar argon 40
19 K potassium 39	20 Ca calcium 40	21 Sc scandium 45	22 Ti titanium 48	23 V vanadium 51	24 Cr chromium 52	25 Mn manganese 55	26 Fe iron 56	27 Co cobalt 59	28 Ni nickel 59	29 Cu copper 64	30 Zn zinc 65	31 Ga gallium 70	32 Ge germanium 73	33 As arsenic 75	34 Se selenium 79	35 Br bromine 80	36 Kr krypton 84
37 Rb rubidium 85	38 Sr strontium 88	39 Y yttrium 89	40 Zr zirconium 91	41 Nb niobium 93	42 Mo molybdenum 96	43 Tc technetium —	44 Ru ruthenium 101	45 Rh rhodium 103	46 Pd palladium 106	47 Ag silver 108	48 Cd cadmium 112	49 In indium 115	50 Sn tin 119	51 Sb antimony 122	52 Te tellurium 128	53 I iodine 127	54 Xe xenon 131
55 Cs caesium 133	56 Ba barium 137	57–71 lanthanoids	72 Hf hafnium 178	73 Ta tantalum 181	74 W tungsten 184	75 Re rhenium 186	76 Os osmium 190	77 Ir iridium 192	78 Pt platinum 195	79 Au gold 197	80 Hg mercury 201	81 Tl thallium 204	82 Pb lead 207	83 Bi bismuth 209	84 Po polonium —	85 At astatine —	86 Rn radon —
87 Fr francium —	88 Ra radium —	89–103 actinoids	104 Rf rutherfordium —	105 Db dubnium —	106 Sg seaborgium —	107 Bh bohrium —	108 Hs hassium —	109 Mt meitnerium —	110 Ds darmstadtium —	111 Rg roentgenium —	112 Cn copernicium —	114 Fl flerovium —	116 Lv livermorium —	—	—	—	—

57 La lanthanum 139	58 Ce cerium 140	59 Pr praseodymium 141	60 Nd neodymium 144	61 Pm promethium —	62 Sm samarium 150	63 Eu europium 152	64 Gd gadolinium 157	65 Tb terbium 159	66 Dy dysprosium 163	67 Ho holmium 165	68 Er erbium 167	69 Tm thulium 169	70 Yb ytterbium 173	71 Lu lutetium 175
89 Ac actinium —	90 Th thorium 232	91 Pa protactinium 231	92 U uranium 238	93 Np neptunium —	94 Pu plutonium —	95 Am americium —	96 Cm curium —	97 Bk berkelium —	98 Cf californium —	99 Es einsteinium —	100 Fm fermium —	101 Md mendelevium —	102 No nobelium —	103 Lr lawrencium —

The volume of one mole of any gas is 24 dm³ at room temperature and pressure (r.t.p.).