



# Cambridge IGCSE™

CANDIDATE  
NAME

CENTRE  
NUMBER

--	--	--	--	--

CANDIDATE  
NUMBER

--	--	--	--

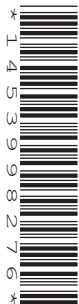

**CO-ORDINATED SCIENCES**

**0654/43**

Paper 4 Theory (Extended)

**October/November 2023**

**2 hours**

You must answer on the question paper.

No additional materials are needed.

## INSTRUCTIONS

- Answer **all** questions.
- Use a black or dark blue pen. You may use an HB pencil for any diagrams or graphs.
- Write your name, centre number and candidate number in the boxes at the top of the page.
- Write your answer to each question in the space provided.
- Do **not** use an erasable pen or correction fluid.
- Do **not** write on any bar codes.
- You may use a calculator.
- You should show all your working and use appropriate units.

## INFORMATION

- The total mark for this paper is 120.
- The number of marks for each question or part question is shown in brackets [ ].
- The Periodic Table is printed in the question paper.

This document has **28** pages. Any blank pages are indicated.

- 1 (a) Fig. 1.1 shows medical notes from a person at risk of developing coronary heart disease (CHD).

Medical notes	
• Age:	68
• Family history:	No coronary heart disease in the family.
• Other notes:	smokes tobacco is a healthy weight eats a balanced diet walks for 10 minutes each week.

Fig. 1.1

- (i) Complete this sentence about coronary heart disease.

Coronary heart disease is caused by a ..... of the coronary arteries. [1]

- (ii) Use Fig. 1.1 to state **two** ways that the person can reduce their risk of developing coronary heart disease.

1 .....

2 ..... [2]

- (iii) The person cannot control **one** of the factors in Fig. 1.1 that puts them at greater risk of developing coronary heart disease.

Identify this factor.

..... [1]

(b) Fig. 1.2 is a photomicrograph of a cross-section of an artery.

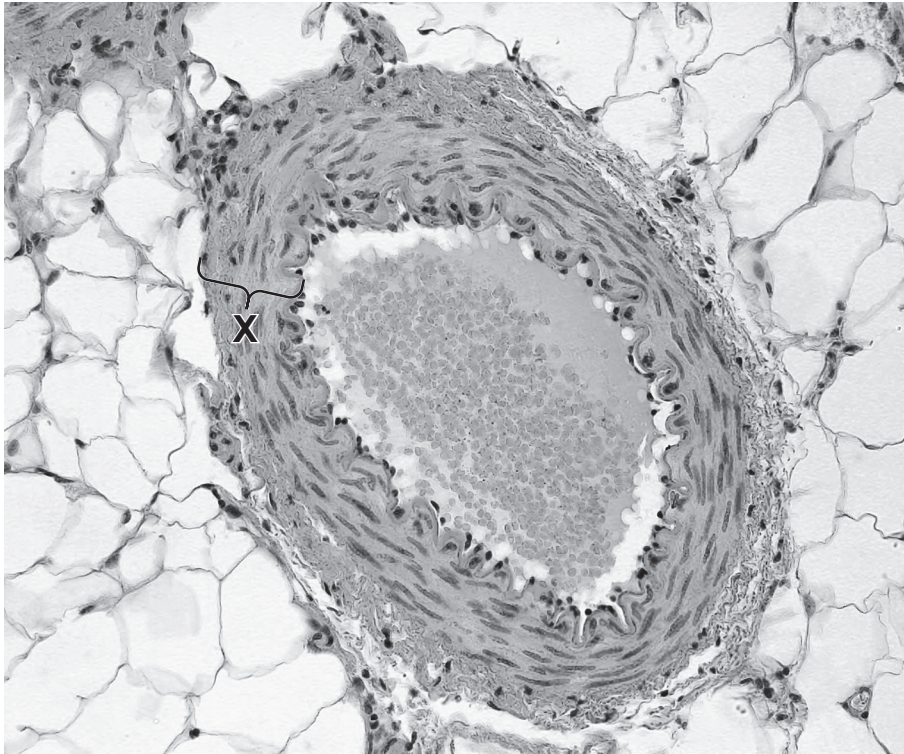

Fig. 1.2

(i) Describe **and** explain the adaptations of the feature labelled **X** in Fig. 1.2 for the transport of blood.

.....

.....

.....

.....

.....

..... [4]

(ii) State the type of circulation that mammals have.

..... [1]

[Total: 9]

2 This question is about metals.

(a) Aluminium is used to make aircraft.

Identify from the list below **one** property of aluminium that makes it suitable for this purpose.

- good conductor of electricity
- good thermal conductor
- low density
- low melting point

[1]

(b) Aluminium is used to make food containers because it is resistant to corrosion.

Explain why aluminium is resistant to corrosion.

.....

.....

..... [2]

(c) Metals can be mixed with other elements to form alloys.

Fig. 2.1 shows the structures of pure aluminium and an alloy of aluminium.

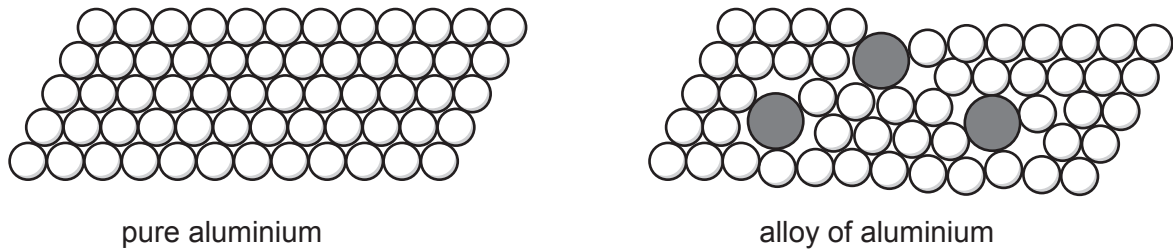

Fig. 2.1

An alloy of aluminium called duralumin is often used to make aircraft instead of pure aluminium.

Explain, in terms of their structures and properties, why the alloy is used instead of pure aluminium.

.....

.....

.....

..... [3]

(d) Steel is an alloy of iron. Steel is used to make car bodies.

The steel is usually coated with zinc before it is painted.

The zinc prevents rusting, even if the zinc layer is damaged.

Describe how the zinc prevents rusting.

.....

.....

..... [2]

(e) Table 2.1 shows a reactivity series for some metals.

**Carbon**, a non-metal, is also shown in Table 2.1.

**Table 2.1**

sodium	most reactive  least reactive
calcium	
magnesium	
<b>carbon</b>	
iron	
copper	

State a metal from Table 2.1 that is extracted from its ore by electrolysis.

Explain your answer.

metal .....

explanation .....

.....

.....

[3]

[Total: 11]

3 Meteoroids are lumps of rock which travel through space.

(a) During its journey through space, a meteoroid travels at a constant speed of 25 000 m/s.

(i) Calculate the time taken for the meteoroid to travel 1000 m.

time = ..... s [2]

(ii) Fig. 3.1 shows a speed–time graph for the meteoroid as it enters the atmosphere of a planet.

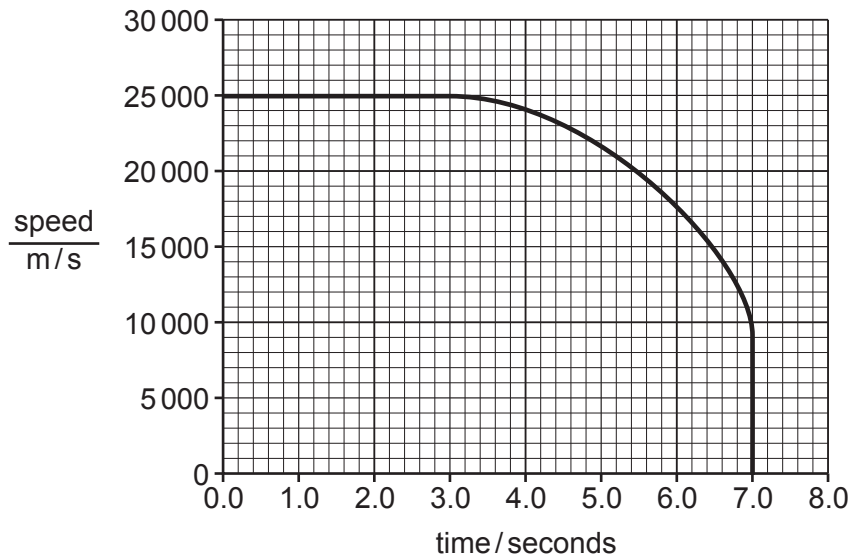

**Fig. 3.1**

Describe the motion of the meteoroid shown in Fig. 3.1.

.....

.....

.....

.....

..... [3]

(b) When the meteoroid lands on Earth, it is called a meteorite.

A small meteorite has a mass of 1720g and a volume of 200 cm<sup>3</sup>.

Calculate the density of the meteorite.

density = ..... g/cm<sup>3</sup> [2]

(c) When meteorites land on Earth, they produce very loud sound waves that travel through all materials including air, solid rock and liquid water.

(i) Describe how sound waves are transmitted in air.

.....  
 ..... [1]

(ii) Draw **one** line from each material to show the average speed of sound in that material.

air	340 m/s
rock	1500 m/s
water	4200 m/s

[1]

[Total: 9]

- 4 (a) A scientist compares the relative concentrations of bacteria and dissolved oxygen in a river before and after fertiliser is added.

Fig. 4.1 is a graph of the results.

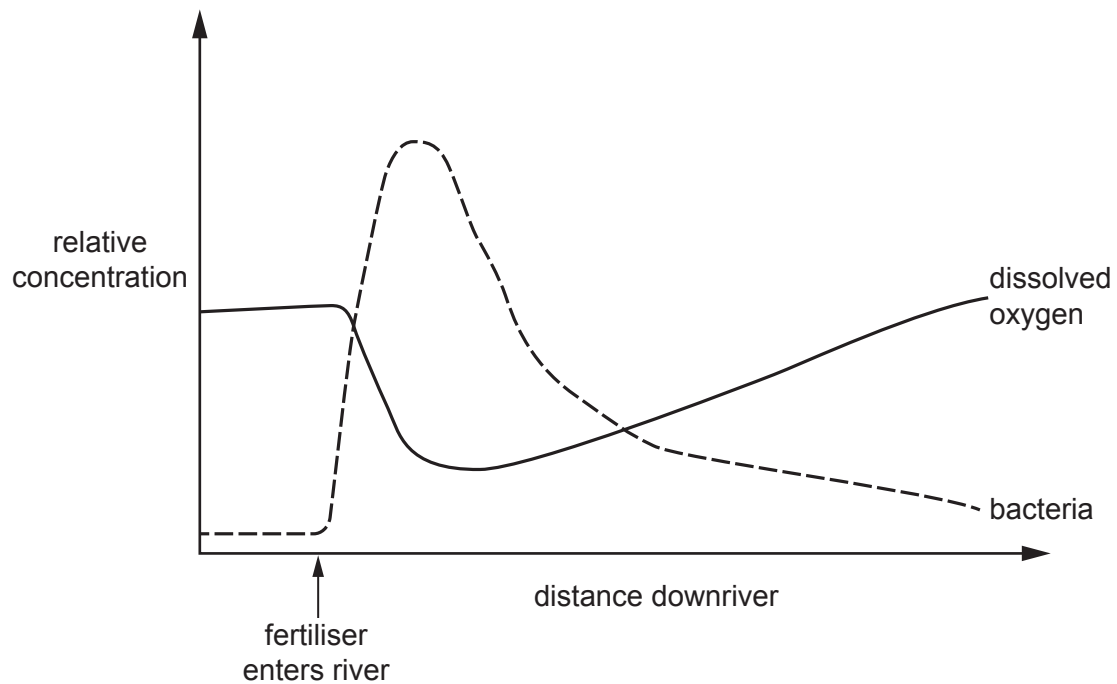

Fig. 4.1

Complete the sentences to describe **and** explain the changes seen in Fig. 4.1.

Fertilisers entering the water contain ..... ions.

An increase in the availability of these ions enables an increase in the .....  
of producers on the surface of the water.

Producers underneath the water are unable to ..... due to a lack of light  
and they die.

The population of bacteria increases as they ..... the dead material.

The concentration of dissolved oxygen decreases because the bacteria need oxygen for the  
process of ..... .

This entire process is called .....

[6]



(b) Bacteria reproduce by a type of asexual reproduction.

(i) State the type of cell division used in asexual reproduction.

..... [1]

(ii) Describe **two** ways that asexual reproduction is different from sexual reproduction.

1 .....

.....

2 .....

.....

[2]

(iii) State the name of **one** type of cell adapted for sexual reproduction in humans.

..... [1]

[Total: 10]

- 5 (a) Particles can be atoms, ions or molecules. Particles either form pure substances or mixtures.

Draw **one** line from each word to the correct definition. One has been done for you.

atom	substance made of only one type of atom
element	an atom or group of atoms with an electrical charge
ion	two or more atoms joined together
mixture	two or more different substances that are <b>not</b> joined together
molecule	the smallest neutral part of an element

The diagram consists of two columns of rectangular boxes. The left column contains the terms: atom, element, ion, mixture, and molecule. The right column contains the definitions: substance made of only one type of atom, an atom or group of atoms with an electrical charge, two or more atoms joined together, two or more different substances that are **not** joined together, and the smallest neutral part of an element. A single line is drawn from the right side of the 'molecule' box to the left side of the 'two or more atoms joined together' box.

[4]

- (b) Particles can diffuse at different rates.

Fig. 5.1 shows an experiment to investigate diffusion of gas particles.

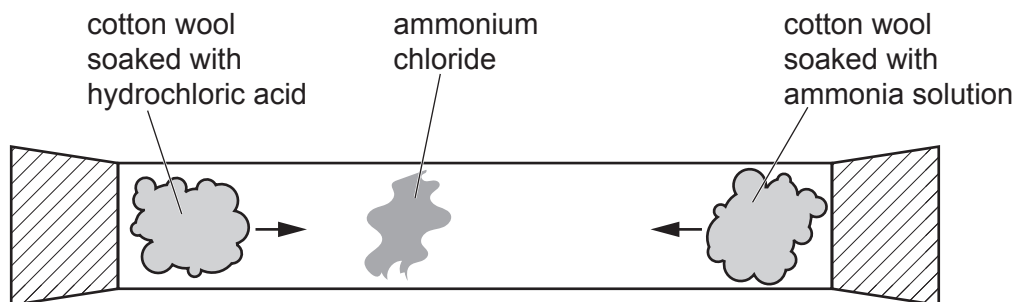

Fig. 5.1

Ammonia gas,  $\text{NH}_3$ , and hydrogen chloride gas,  $\text{HCl}$ , diffuse along the tube.

When the gases meet, they react to form a white cloud of ammonium chloride.

- (i) The ammonium chloride forms at the end of the tube furthest from the ammonia.

Explain why, in terms of the movement of molecules.

.....  
 .....  
 ..... [2]

- (ii) Calculate the volume occupied by 5.1 g of ammonia gas.

The molar gas volume at room temperature and pressure is  $24 \text{ dm}^3$ .

Show your working.

[ $A_r$ : H, 1; N, 14]

volume of ammonia gas = .....  $\text{dm}^3$  [3]

[Total: 9]

6 Fig. 6.1 shows an electric refrigerator.



Fig. 6.1

(a) The cooling unit inside the refrigerator is placed at the top of the refrigerator.

(i) State the name of the process which transfers most thermal energy from the food to the cooling unit inside the refrigerator.

..... [1]

(ii) Explain, in terms of density changes, why the cooling unit being fitted at the top of the refrigerator allows all of the air inside to be cooled.

.....  
 .....  
 .....  
 .....  
 ..... [3]

- (b) The refrigerator uses the compression and expansion of gases in order to transfer thermal energy to the outside of the refrigerator.

Complete Table 6.1 to show how the pressure of a fixed mass of gas changes with temperature and with volume.

**Table 6.1**

temperature	volume	pressure
increases	kept constant	
remains constant	increases	

[1]

- (c) The cooling unit in the refrigerator uses a motor.

Fig. 6.2 shows a simple d.c. motor.

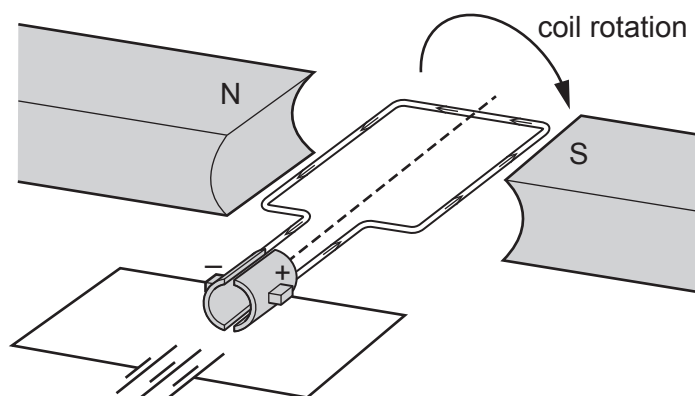

**Fig. 6.2**

Describe **two** ways to make a motor turn more slowly.

- 1 .....
- .....
- 2 .....
- .....

[2]

[Total: 7]

7 (a) Fig. 7.1 is a diagram of a cross-section of a leaf.

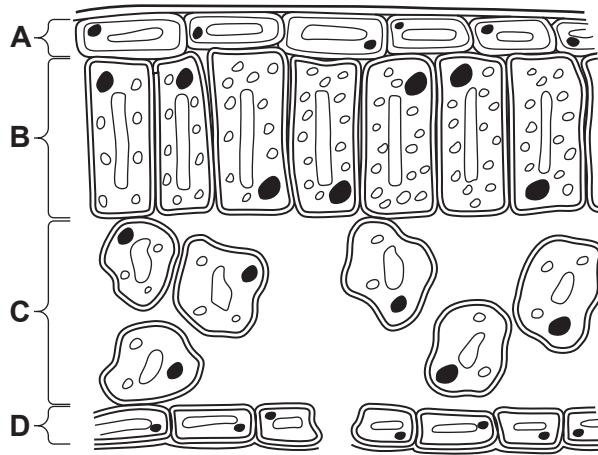

Fig. 7.1

(i) State the names of the parts labelled **A** and **B** in Fig. 7.1.

**A** .....

**B** .....

[2]

(ii) Describe **one** way the part labelled **C** in Fig. 7.1 is adapted for gas exchange.

.....  
 .....  
 .....  
 ..... [2]

(iii) Draw a label line and the correct name on Fig. 7.1 to identify **one** cell that controls the entry of gas into the leaf. [2]

(b) Describe the use of **three** different carbohydrates produced in a plant.

1 .....

2 .....

3 .....

..... [3]

[Total: 9]

8 Electrolysis is used to break down ionic compounds.

(a) Complete the sentences about electrolysis.

Choose words from the list.

Each word may be used once, more than once, or not at all.

**anions      cations      electrolytes      gain      lose      share**

Electrolysis is the breakdown of an ionic compound when molten or in aqueous solution.

The positive ions move to the negative electrode and ..... electrons to form atoms. The ..... move to the positive electrode and ..... electrons to form atoms.

[3]

(b) In an electrolysis experiment, using carbon electrodes, aqueous copper(II) sulfate is broken down.

State the product made at each electrode.

anode .....

cathode .....

[2]

(c) Aluminium is extracted from aluminium oxide by electrolysis.

Aluminium ions,  $Al^{3+}$ , make aluminium,  $Al$ .

Construct the balanced ionic half-equation for the reaction.

..... [2]

[Total: 7]

9 Tellurium is a rare element which exists as several isotopes, some of which are unstable.

(a) A nucleus of tellurium-109 decays by emitting an alpha-particle.

(i) Describe the effect of emitting an alpha-particle on the proton number ( $Z$ ), number of neutrons and nucleon number ( $A$ ) of a nucleus.

proton number ( $Z$ ) .....

number of neutrons: .....

nucleon number ( $A$ ) .....

[2]

(ii) The decay of tellurium-109 produces an isotope of tin.

The half-life of tellurium-109 is 4.63 s.

Calculate the time taken for a sample of pure tellurium-109 to contain 87.5% tin.

time = ..... s [3]



(b) Stable isotopes of tellurium can be used to make solar cells.

(i) State **one** advantage and **one** disadvantage of using solar cells to generate electricity.

advantage .....

.....

disadvantage .....

.....

[2]

(ii) Suggest why it is an advantage for a solar cell to be coloured black.

.....

..... [1]

(iii) Fig. 9.1 shows a panel of solar cells.

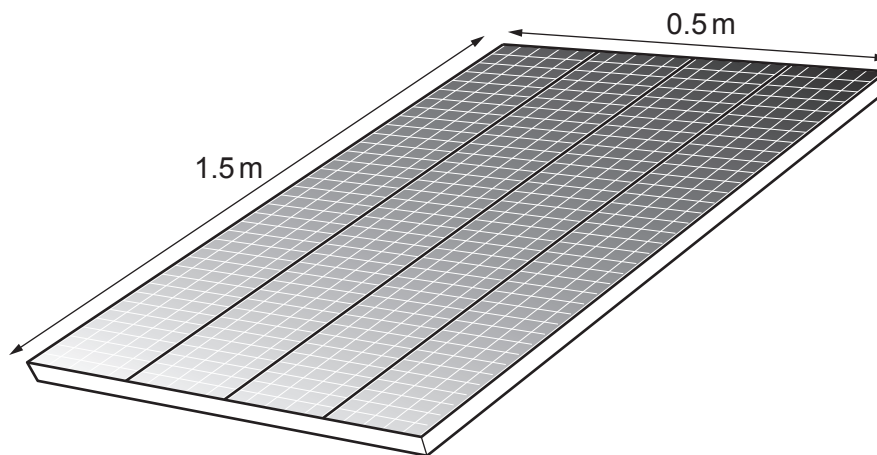

**Fig. 9.1**

On a sunny day, there is  $1400 \text{ W/m}^2$  of sunlight hitting the solar cells shown in Fig. 9.1.

The solar cells have an efficiency of 16%.

Calculate the power output from the solar cells.

power output = ..... W [3]

[Total: 11]

**[Turn over**

10 (a) Fig. 10.1 shows the effect of adrenaline on blood glucose concentration.

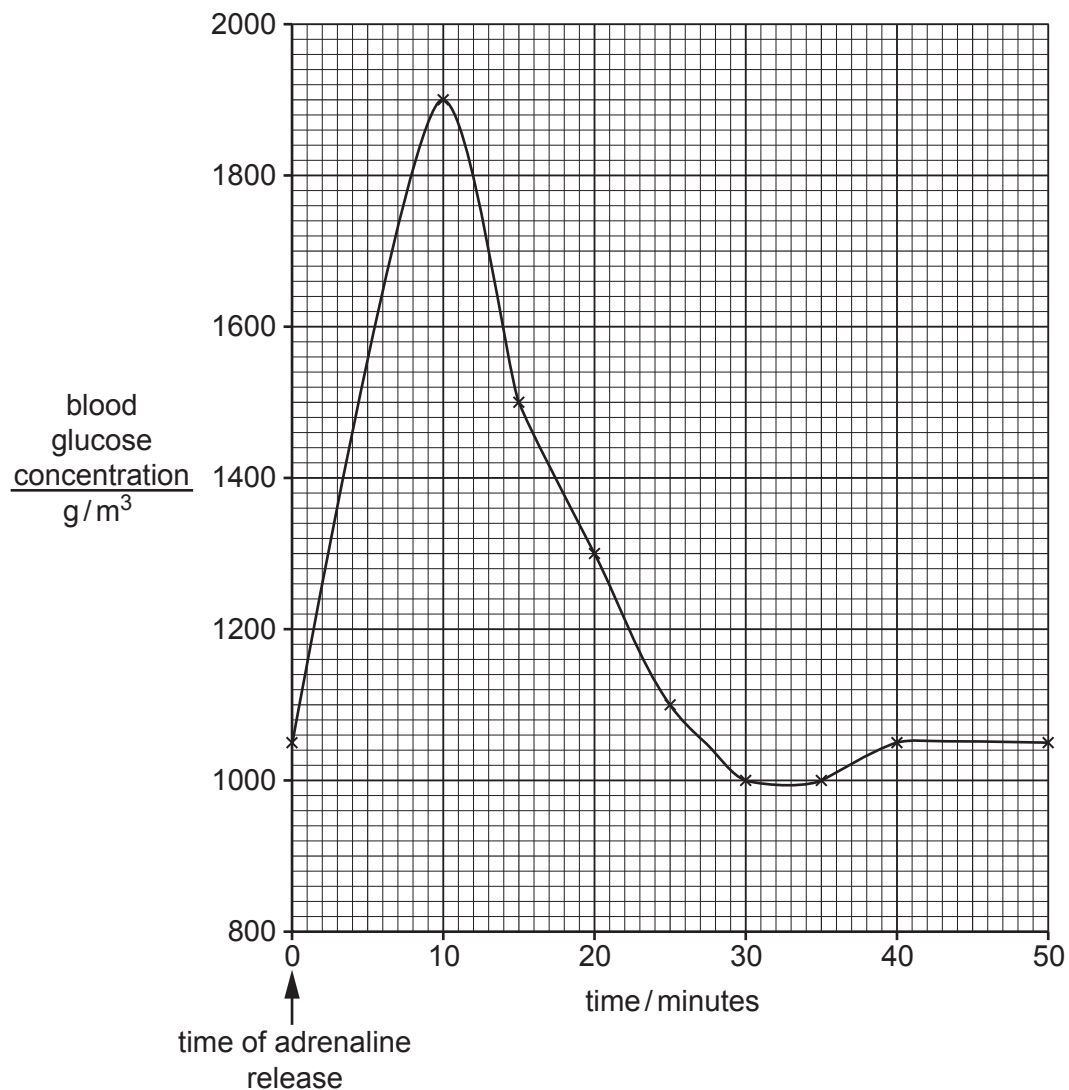

Fig. 10.1

(i) Calculate the percentage increase in blood glucose concentration between 0 and 10 minutes in Fig. 10.1.

blood glucose concentration at 0 minutes ..... g/m<sup>3</sup>

blood glucose concentration at 10 minutes ..... g/m<sup>3</sup>

percentage increase = ..... % [2]

- (ii) Explain the changes to blood glucose concentration shown between **10** and **30** minutes in Fig. 10.1.

.....

.....

.....

.....

..... [3]

- (b) State the name of **one** hormone, apart from adrenaline, that increases the blood glucose concentration.

..... [1]

- (c) Table 10.1 contains some definitions of processes that occur in the alimentary canal.

Complete Table 10.1 with the terms of each definition.

**Table 10.1**

term	definition
	breakdown of food into smaller pieces without chemical change to the food molecules
	movement of digested food molecules into the cells of the body where they are used, becoming part of the cells
	movement of digested food molecules through the wall of the intestine into the blood

[3]

(d) Fig. 10.2 is a diagram of a structure found lining the small intestine.

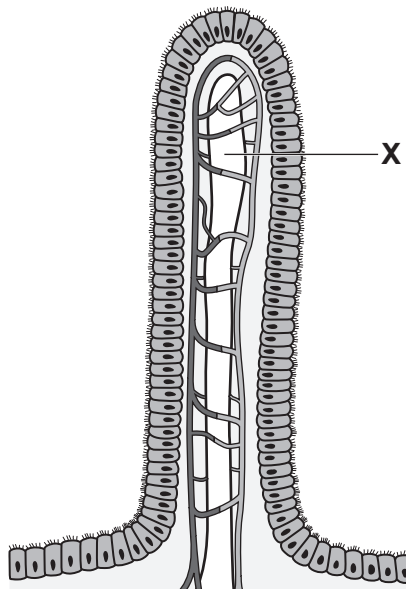

Fig. 10.2

(i) State the name of the structure shown in Fig. 10.2.

..... [1]

(ii) State the name **and** function of the part labelled **X** in Fig. 10.2.

name .....

function .....

[2]

[Total: 12]

11 (a) An aqueous solution of dilute hydrochloric acid is acidic.

(i) Suggest the pH of an aqueous solution of dilute hydrochloric acid.

pH = ..... [1]

(ii) State the definition of an acid in terms of proton transfer.

..... [1]

(b) A student investigates the rate of reaction between magnesium and dilute hydrochloric acid.

Magnesium chloride and a gas are made.

(i) Construct the word equation for the reaction.

..... + ..... → ..... + ..... [1]

(ii) State how the rate of reaction can be increased.

Tick (✓) **one** box.

adding water to the dilute hydrochloric acid

decreasing the mass of the magnesium

increasing the volume of the dilute hydrochloric acid

using powdered magnesium instead of magnesium ribbon

[1]

- (iii) The student measures the volume of hydrogen gas made until all the magnesium has reacted.

Fig. 11.1 shows a graph of the results.

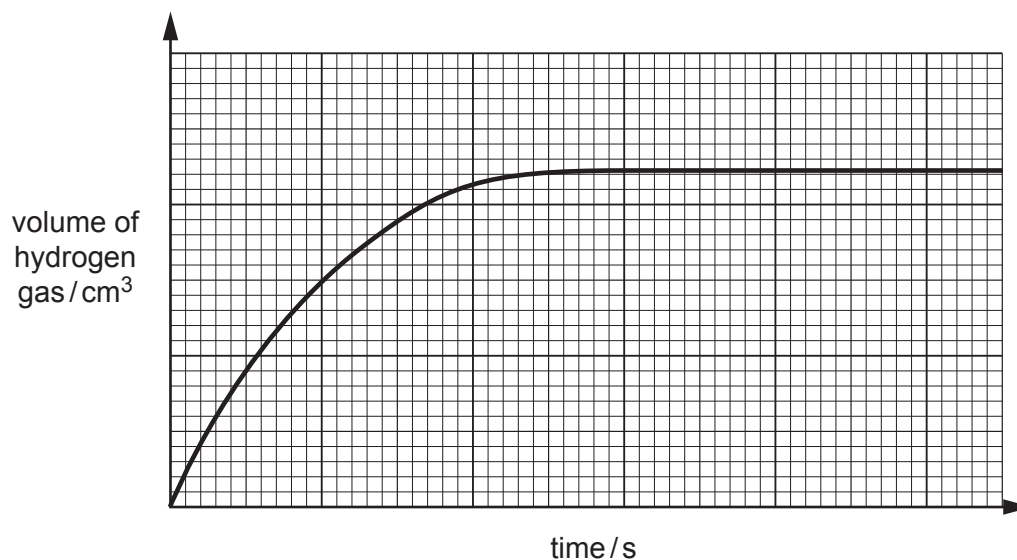

Fig. 11.1

Sketch, on Fig. 11.1, the results that the student would obtain by repeating the experiment under the same conditions but using **more concentrated** hydrochloric acid. [2]

- (iv) Explain why the rate of reaction can be increased by increasing the **temperature** of the dilute hydrochloric acid.

Use ideas about particles in your answer.

.....

.....

.....

..... [3]

- (c) The student adds 0.1 g of magnesium to 40 cm<sup>3</sup> of 0.5 mol/dm<sup>3</sup> hydrochloric acid.

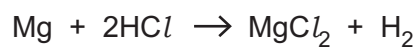

Show, by calculation, that the magnesium is the **limiting reactant**.

[A<sub>r</sub>: Mg, 24]

[4]

[Total: 13]

12 A student investigates light dependent resistors (LDRs).

Fig. 12.1 shows the circuit the student uses.

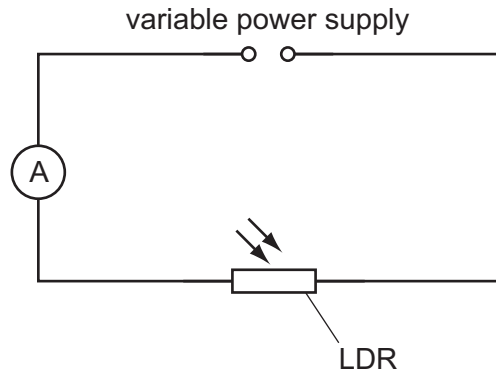

Fig. 12.1

(a) The ammeter in Fig. 12.1 reads 0.24A.

(i) Calculate the amount of charge flowing through the LDR each minute.

State the unit for your answer.

charge = ..... unit ..... [3]

(ii) The student shines a bright desk lamp on the LDR.

State and explain the effect this has on the ammeter reading.

effect .....

explanation .....

.....

.....

[2]



- (iii) The desk lamp emits light with wavelengths ranging from  $3.8 \times 10^{-7}\text{m}$  to  $7.5 \times 10^{-7}\text{m}$ .  
Calculate the minimum frequency of light emitted by the desk lamp.

minimum frequency = ..... Hz [3]

- (b) The student calculates the resistance of the LDR using the current reading from the ammeter.  
State what other measurement is required for this calculation.

..... [1]

- (c) The variable power supply used by the student uses a transformer to reduce the output.

The current in the primary coil of the transformer is 10.5A and the current in the secondary coil is 4.2A.

The primary coil contains 360 turns and the transformer can be assumed to be 100% efficient.

Calculate the number of turns in the secondary coil.

number of turns = ..... [4]

[Total: 13]



**BLANK PAGE**

---

Permission to reproduce items where third-party owned material protected by copyright is included has been sought and cleared where possible. Every reasonable effort has been made by the publisher (UCLES) to trace copyright holders, but if any items requiring clearance have unwittingly been included, the publisher will be pleased to make amends at the earliest possible opportunity.

To avoid the issue of disclosure of answer-related information to candidates, all copyright acknowledgements are reproduced online in the Cambridge Assessment International Education Copyright Acknowledgements Booklet. This is produced for each series of examinations and is freely available to download at [www.cambridgeinternational.org](http://www.cambridgeinternational.org) after the live examination series.

Cambridge Assessment International Education is part of Cambridge Assessment. Cambridge Assessment is the brand name of the University of Cambridge Local Examinations Syndicate (UCLES), which is a department of the University of Cambridge.

## The Periodic Table of Elements

		Group															
I	II	III	IV	V	VI	VII	VIII						VIII				
3 Li lithium 7	4 Be beryllium 9	1 H hydrogen 1	5 B boron 11	6 C carbon 12	7 N nitrogen 14	8 O oxygen 16	9 F fluorine 19	10 Ne neon 20						18 Ar argon 40			
11 Na sodium 23	12 Mg magnesium 24	<b>Key</b> atomic number atomic symbol name relative atomic mass		13 Al aluminium 27	14 Si silicon 28	15 P phosphorus 31	16 S sulfur 32	17 Cl chlorine 35.5						36 Kr krypton 84			
19 K potassium 39	20 Ca calcium 40	21 Sc scandium 45	22 Ti titanium 48	23 V vanadium 51	24 Cr chromium 52	25 Mn manganese 55	26 Fe iron 56	27 Co cobalt 59	28 Ni nickel 59	29 Cu copper 64	30 Zn zinc 65	31 Ga gallium 70	32 Ge germanium 73	33 As arsenic 75	34 Se selenium 79	35 Br bromine 80	36 Kr krypton 84
37 Rb rubidium 85	38 Sr strontium 88	39 Y yttrium 89	40 Zr zirconium 91	41 Nb niobium 93	42 Mo molybdenum 96	43 Tc technetium —	44 Ru ruthenium 101	45 Rh rhodium 103	46 Pd palladium 106	47 Ag silver 108	48 Cd cadmium 112	49 In indium 115	50 Sn tin 119	51 Sb antimony 122	52 Te tellurium 128	53 I iodine 127	54 Xe xenon 131
55 Cs caesium 133	56 Ba barium 137	57–71 lanthanoids	72 Hf hafnium 178	73 Ta tantalum 181	74 W tungsten 184	75 Re rhenium 186	76 Os osmium 190	77 Ir iridium 192	78 Pt platinum 195	79 Au gold 197	80 Hg mercury 201	81 Tl thallium 204	82 Pb lead 207	83 Bi bismuth 209	84 Po polonium —	85 At astatine —	86 Rn radon —
87 Fr francium —	88 Ra radium —	89–103 actinoids	104 Rf rutherfordium —	105 Db dubnium —	106 Sg seaborgium —	107 Bh bohrium —	108 Hs hassium —	109 Mt meitnerium —	110 Ds darmstadtium —	111 Rg roentgenium —	112 Cn copernicium —	114 Fl flerovium —	116 Lv livermorium —				

lanthanoids

57 La lanthanum 139	58 Ce cerium 140	59 Pr praseodymium 141	60 Nd neodymium 144	61 Pm promethium —	62 Sm samarium 150	63 Eu europium 152	64 Gd gadolinium 157	65 Tb terbium 159	66 Dy dysprosium 163	67 Ho holmium 165	68 Er erbium 167	69 Tm thulium 169	70 Yb ytterbium 173	71 Lu lutetium 175
89 Ac actinium —	90 Th thorium 232	91 Pa protactinium 231	92 U uranium 238	93 Np neptunium —	94 Pu plutonium —	95 Am americium —	96 Cm curium —	97 Bk berkelium —	98 Cf californium —	99 Es einsteinium —	100 Fm fermium —	101 Md mendelevium —	102 No nobelium —	103 Lr lawrencium —

actinoids

The volume of one mole of any gas is 24 dm<sup>3</sup> at room temperature and pressure (r.t.p.).