



Cambridge IGCSE™

CANDIDATE
NAME

CENTRE
NUMBER

--	--	--	--	--

CANDIDATE
NUMBER

--	--	--	--

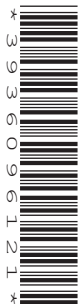

COMBINED SCIENCE

0653/32

Paper 3 Theory (Core)

February/March 2020

1 hour 15 minutes

You must answer on the question paper.

No additional materials are needed.

INSTRUCTIONS

- Answer **all** questions.
- Use a black or dark blue pen. You may use an HB pencil for any diagrams or graphs.
- Write your name, centre number and candidate number in the boxes at the top of the page.
- Write your answer to each question in the space provided.
- Do **not** use an erasable pen or correction fluid.
- Do **not** write on any bar codes.
- You may use a calculator.
- You should show all your working and use appropriate units.

INFORMATION

- The total mark for this paper is 80.
- The number of marks for each question or part question is shown in brackets [].
- The Periodic Table is printed in the question paper.

This document has **24** pages. Blank pages are indicated.

- 1 (a) Fig. 1.1 is a diagram of a human heart.

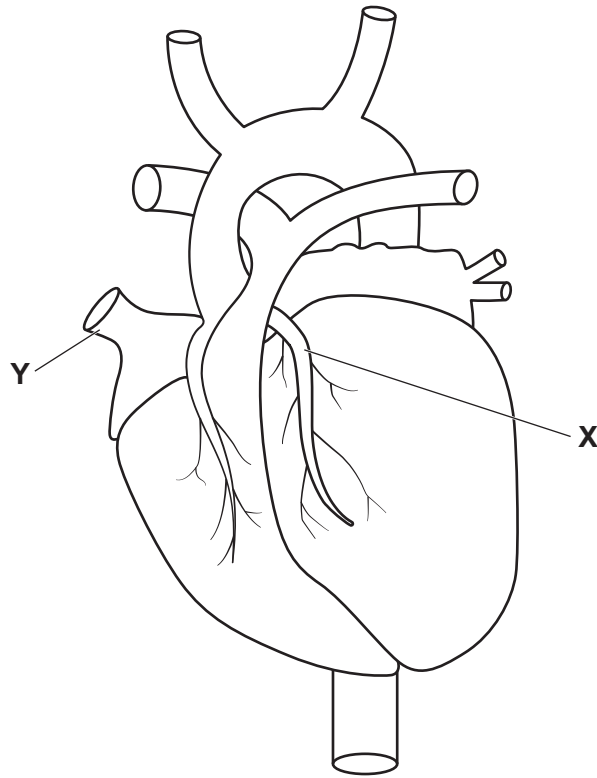

Fig. 1.1

- (i) Name artery **X** shown in Fig. 1.1.

.....

[1]

- (ii) Vein **Y** brings blood to the heart from the body.

Name vein **Y** shown in Fig. 1.1.

.....

[1]

- (iii) Name the structures that make sure there is one-way flow of blood through the heart.

..... [1]

(iv) Fig. 1.2 is a diagram of the cross-section of three different blood vessels, **P**, **Q** and **R**.

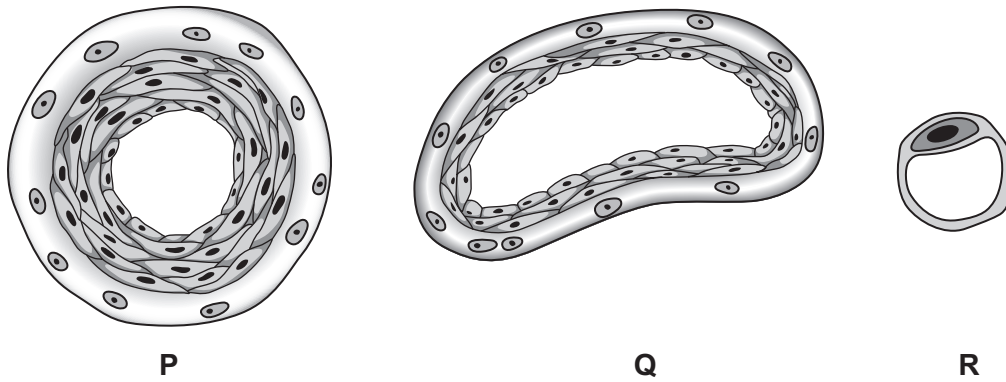

Fig. 1.2

Identify which blood vessel, **P**, **Q** or **R**, represents a vein.
Explain your answer.

blood vessel **P**, **Q** or **R**

explanation

.....

[2]

(b) Fig. 1.3 shows the pulse rate of two students before, during and after exercise.

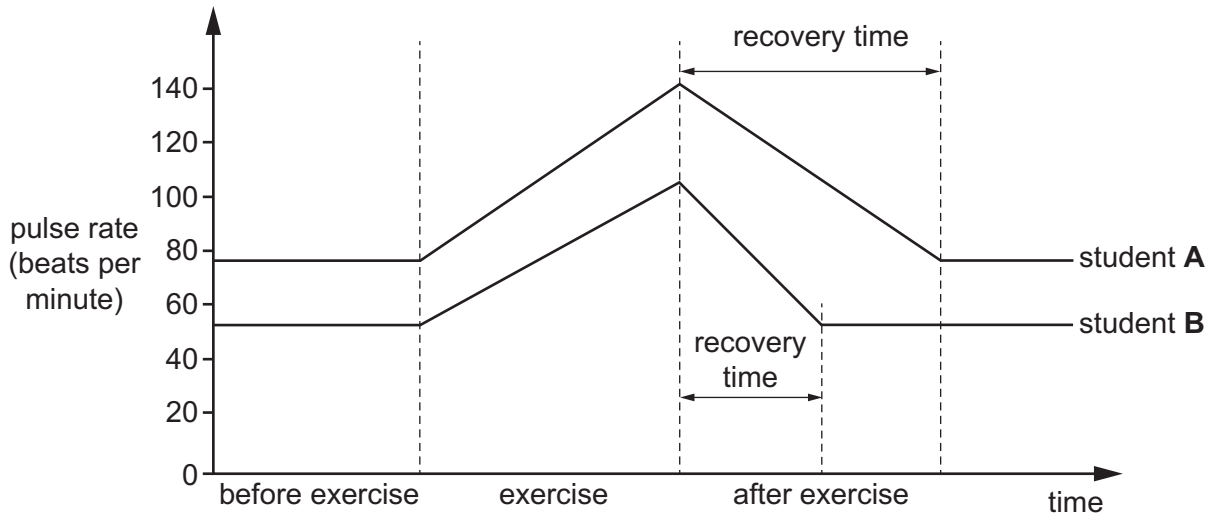

Fig. 1.3

Describe **one** similarity and **two** differences in the pulse rates of students **A** and **B** shown in Fig. 1.3.

similarity

.....

difference 1

.....

difference 2

.....

[3]

[Total: 8]

- 2 (a) A student investigates three solid elements, **X**, **Y** and **Z**.

Element **X** is a dark grey solid. When it is warmed it turns to a purple vapour.

Element **Y** is a soft grey solid. It reacts vigorously with water.

Element **Z** is a dense grey solid. It has a high melting point.

- (i) Use the letters **X**, **Y** and **Z** to identify:

a Group I element

a Group VII element

a transition element.

[2]

- (ii) Describe the trend in the melting points of the elements going down Group I.

.....
 [1]

- (b) The student then investigates four other solid metals **P**, **Q**, **R** and **S**.

He adds equal sized pieces of each metal to cold water and to dilute hydrochloric acid.

Some of his observations are shown in Fig. 2.1.

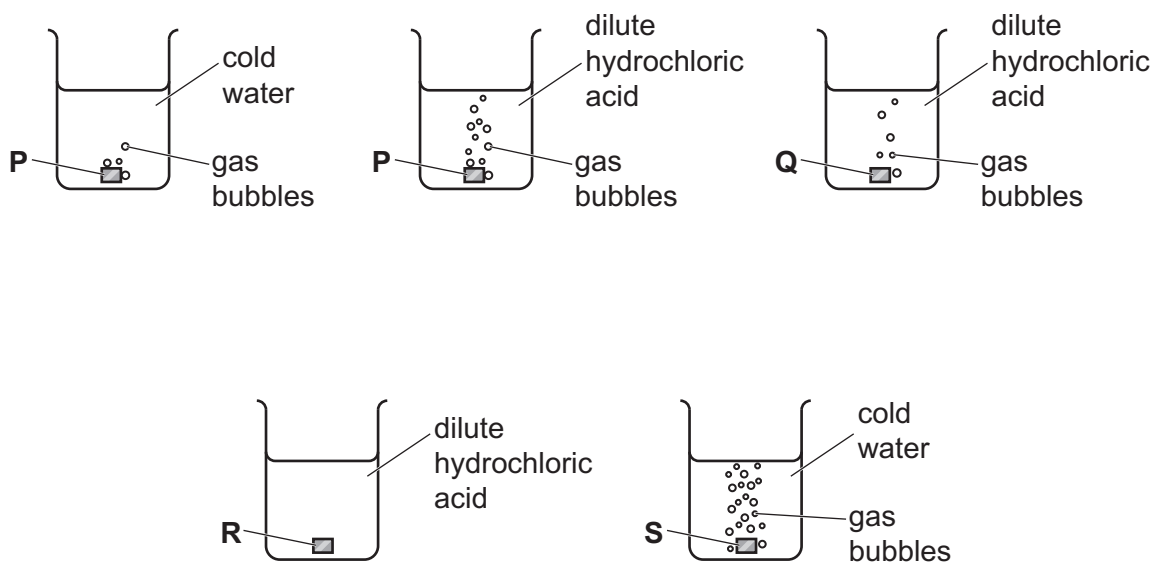

Fig. 2.1

(i) Use the letters **P**, **Q**, **R** and **S** to identify these four metals.

calcium

magnesium

iron

copper

[2]

(ii) Suggest **two** ways of increasing the rate of reaction of metal **Q** with hydrochloric acid.

1

2

[2]

(iii) Identify the gas that is formed when metal **S** reacts with dilute hydrochloric acid.

..... [1]

(iv) When metal **S** reacts with dilute hydrochloric acid, the temperature of the mixture increases.

State the name given to a chemical reaction that causes the temperature to increase.

..... [1]

[Total: 9]

- 3 Fig. 3.1 shows liquid (molten) iron being poured from a furnace into a mould to form a rectangular block of iron (iron bar).

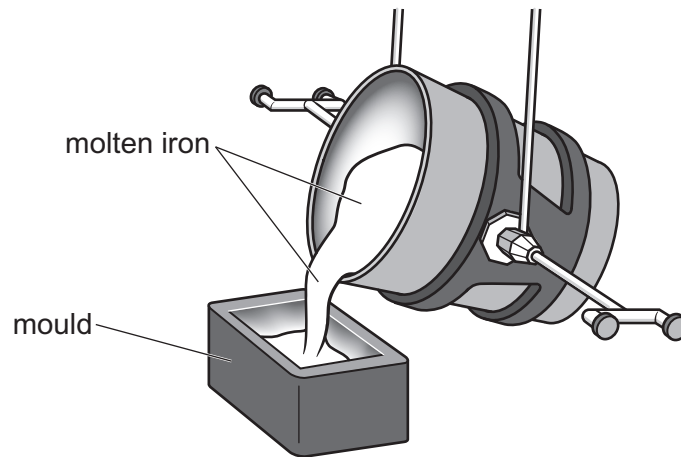

Fig. 3.1

Fig. 3.2 shows the solid iron bar after it has cooled down.

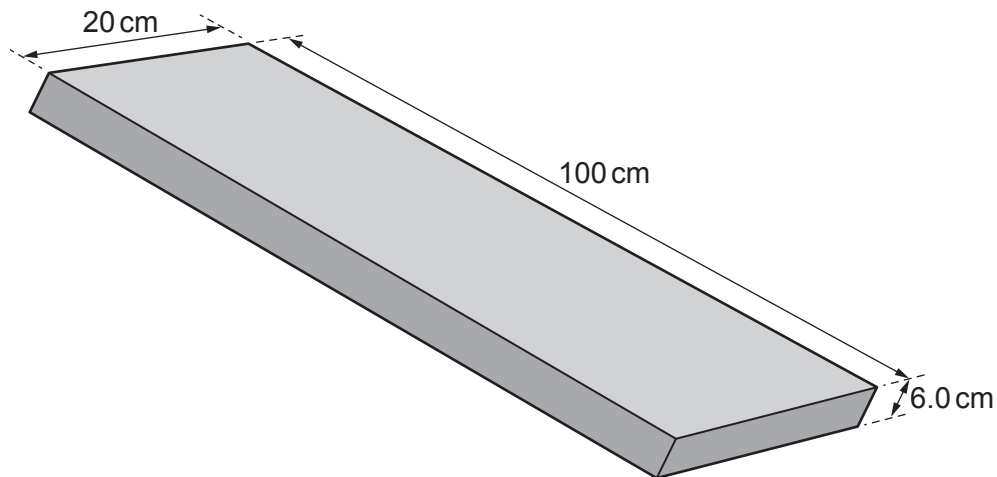

Fig. 3.2

- (a) (i) The bar is 100 cm long, 20 cm wide and 6.0 cm thick.

Calculate the volume of the bar.

volume = cm³ [1]

- (ii) The mass of the iron bar is 94 kg.

Calculate the mass of the iron bar in grams.

mass = g [1]

(iii) Use your answers to (a)(i) and (a)(ii) to calculate the density of iron.

density = g/m³ [2]

(b) As the molten iron cools and turns to solid iron, changes occur in the arrangement of iron atoms.

Describe **one** way in which the arrangement of atoms in solid iron is different from the arrangement of atoms in liquid (molten) iron.

.....
..... [1]

(c) Describe how the motion of the iron atoms changes as the molten iron cools, turns to a solid, and the solid iron cools.

.....
.....
..... [2]

(d) The melting point of iron is 1538 °C.

Suggest why a liquid-in-glass thermometer **cannot** be used to measure the temperature of molten iron.

.....
..... [1]

[Total: 8]

4 (a) Fig. 4.1 shows a cross-section of a leaf as viewed under a microscope.

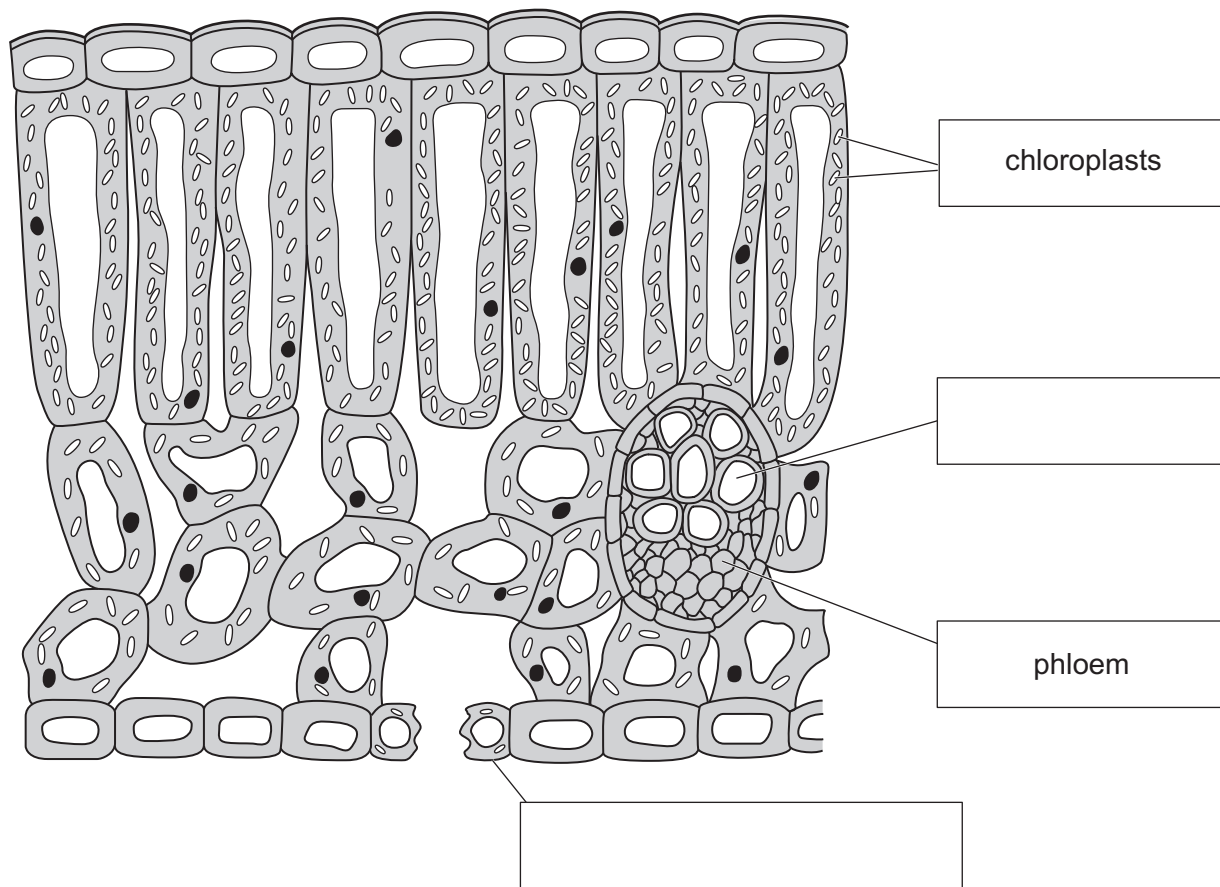

Fig. 4.1

(i) Complete the labels on Fig. 4.1, using words from the list.

- | | | |
|---------|-----------------|---------------|
| cuticle | guard cell | palisade cell |
| stomata | upper epidermis | xylem |

[2]

(ii) State the function of a chloroplast.

.....
 [1]

(iii) State the function of phloem.

.....
 [1]

(b) The leaf of a plant produces glucose.

(i) Plants and animals use glucose to make two different larger molecules for storage.

Name **one** of these larger molecules.

..... [1]

(ii) Glucose is needed by plants and animals for growth.

Complete the sentence to define the term *growth*.

Growth is defined as a increase in size. [1]

(iii) Glucose is a carbohydrate.

List the **three** chemical elements that make up carbohydrates.

1

2

3

[1]

(c) The leaf of a plant needs water for photosynthesis.

The statements show the pathway taken by water from the soil to the leaf.

The statements are **not** in the correct order.

Use numbers 1 to 5 to show the correct order.

The third statement has been identified.

lost through the stomata as water vapour	
enters mesophyll cells of leaf	
passes through root cortex cells	
passes into xylem	3
taken in by root hair cells	

[2]

[Total: 9]

- 5 Refinery gas, gasoline and gas oil are fuels obtained from petroleum in the process shown in Fig. 5.1.

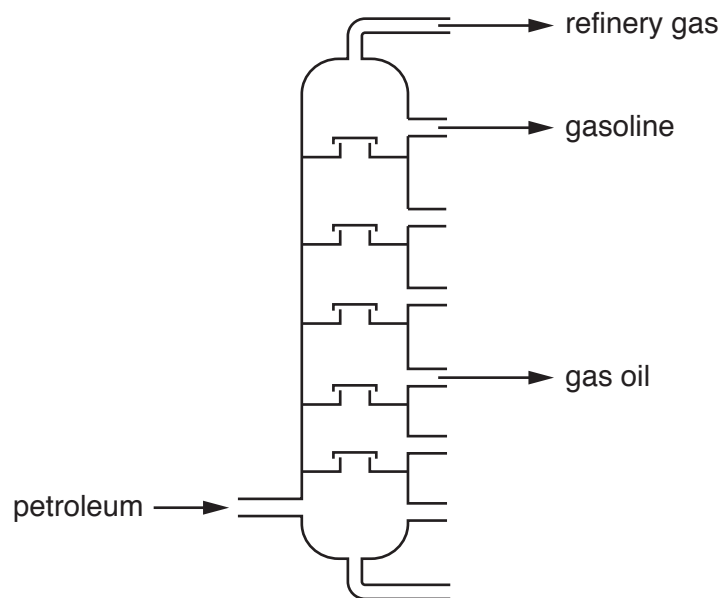

Fig. 5.1

- (a) Suggest **one** use for bottled refinery gas fuel.

..... [1]

- (b) Petroleum is a mixture that contains alkanes.

Alkanes are saturated compounds that contain carbon and hydrogen atoms only.

The complete combustion of alkanes forms water and one other compound.

- (i) Name the type of compound that contains carbon and hydrogen atoms only.

..... [1]

- (ii) Identify **one other** compound that is formed during the complete combustion of alkanes.

..... [1]

- (iii) Describe **one** chemical test for water and give the positive result.

test

result

[2]

- (c) Methane, CH₄, is an alkane.

The structure of a molecule of methane is shown in Fig. 5.2.

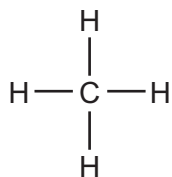

Fig. 5.2

- (i) Name the type of bonding in methane.

..... [1]

- (ii) Explain how bonds form between carbon atoms and hydrogen atoms in methane.

Use ideas about electrons.

.....
 [1]

- (d) Ethene is an alkene.

Alkenes are unsaturated compounds.

- (i) Describe the difference in the structure of molecules of alkenes and alkanes.

Use ideas about bonds.

.....
 [1]

- (ii) Name the addition polymer that forms from ethene monomer units.

..... [1]

[Total: 9]

- 6 Fig. 6.1 shows a crane lifting a load up the side of a building. The crane uses an electric motor to lift the load.

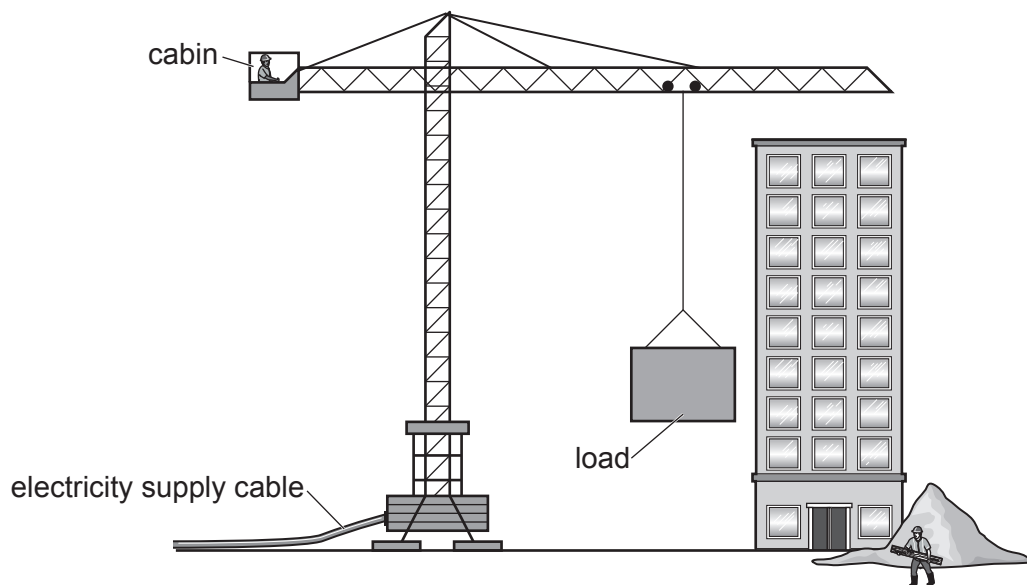
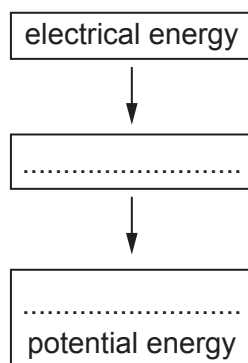

Fig. 6.1

- (a) (i) Complete the sequence of useful energy transfers that occur as the crane lifts the load from the ground to the top of the building.



[2]

- (ii) The electrical energy supplied is 250 000 J. When the load stops at the top of the building, the gain in potential energy by the load is 150 000 J.

State what has happened to most of the rest of the energy supplied.

..... [1]

(b) The crane lifts the load from rest on the ground with an upward force of 6000 N.

The load weighs 5000 N.

(i) Fig. 6.2 shows the load attached to a rope for lifting the load.

On Fig. 6.2 draw force arrows to show the weight and the lifting force acting on the load.

Label the force arrows with their values.

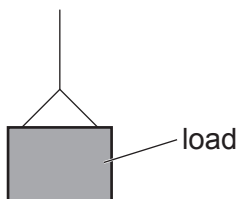

Fig. 6.2

[2]

(ii) Calculate the resultant force on the load.

resultant force = N [1]

(iii) The resultant force causes the load to move upwards.

Describe the upward motion of the load.

..... [1]

(c) The crane is operated by a woman in the cabin at the top of the crane. Before starting to lift the load, she shouts a warning to a worker on the ground.

The distance from the woman to the worker is 30 m.

Speed of sound in air = 330 m/s.

Calculate the time taken for the shouted warning to reach the worker.

time = s [2]

[Total: 9]

[Turn over

7 (a) Fig. 7.1 shows part of the alimentary canal and associated organs.

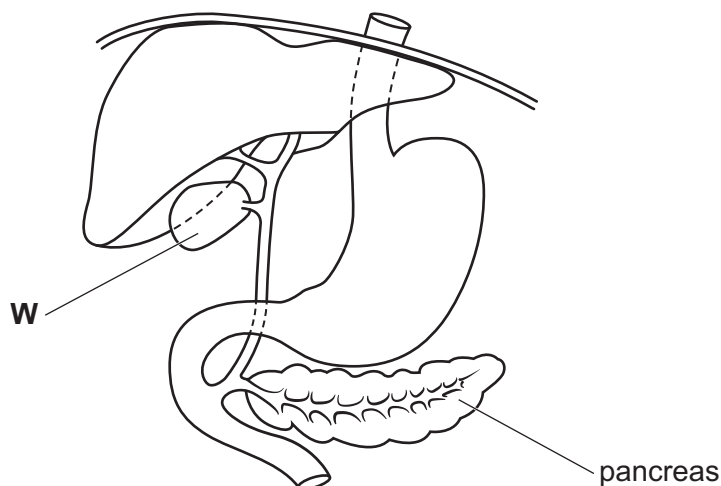

Fig. 7.1

(i) Name the part **W** shown in Fig. 7.1.

.....

[1]

(ii) Some people need to have their pancreas removed due to illness.

Describe how removing the pancreas may affect the person's digestion.

.....

[2]

(iii) The pancreas also produces hormones.

Place ticks (✓) in **two** boxes to show the correct ideas about hormones.

alter the activity of organs	
HIV is one example of a hormone	
they are chemical substances	
produced by target organs	
transported in red blood cells	

[2]

(b) Fig. 7.2 shows a food web.

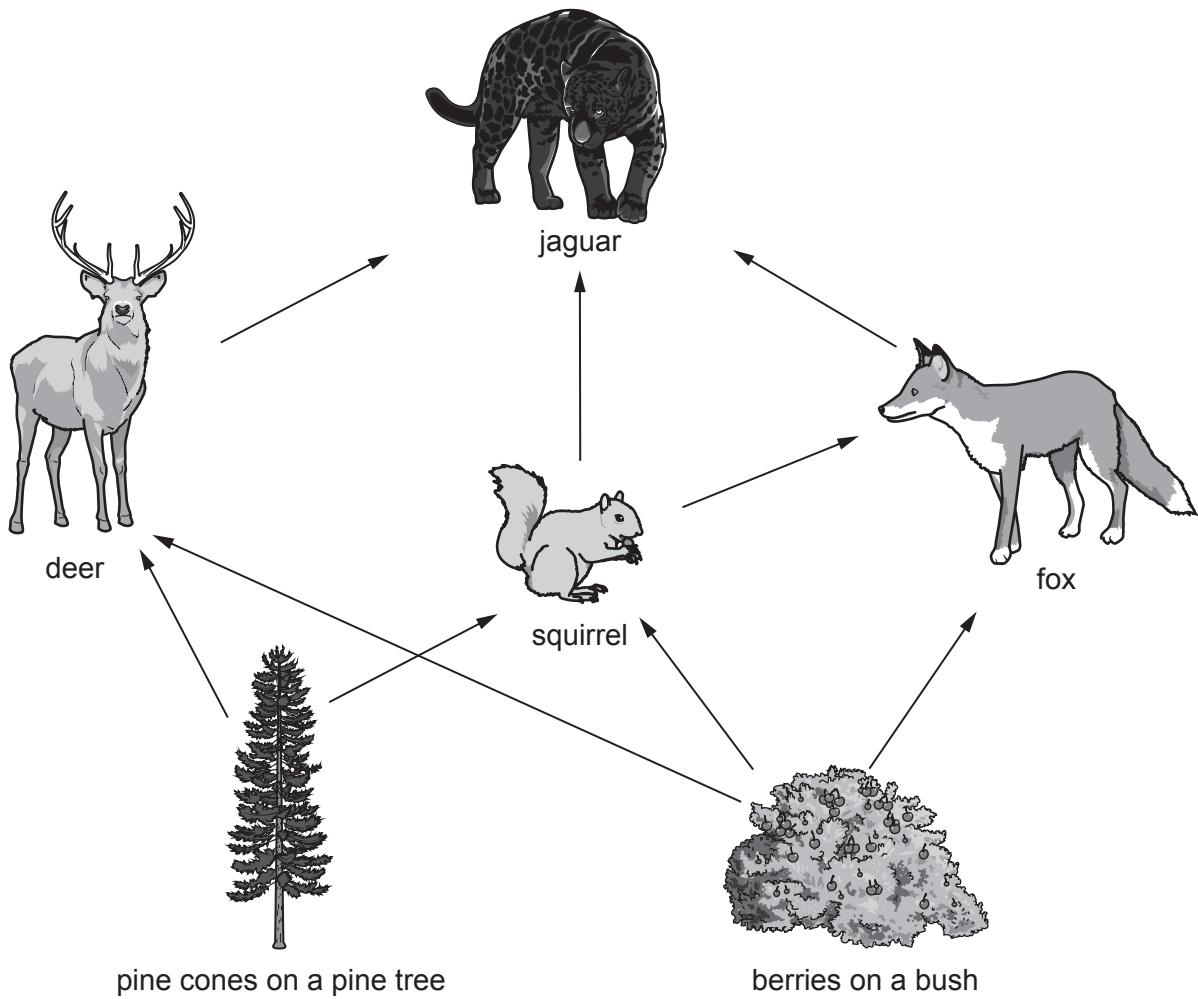

Fig. 7.2

(i) Identify **one** animal shown in Fig. 7.2 that feeds on the pine tree.

..... [1]

(ii) The fox is both a primary consumer and a secondary consumer.

Use the names of organisms shown in Fig. 7.2 to complete these sentences to explain why.

The fox is a **primary** consumer when

.....

The fox is a **secondary** consumer when

.....

[2]

(iii) Berries contain seeds.

Seeds germinate and grow into new plants.

State **two** environmental conditions needed for germination of seeds.

1

2

[2]

[Total: 10]

BLANK PAGE

8 Sodium chloride, NaCl , is an ionic compound.

(a) Name **one** method of obtaining solid sodium chloride from aqueous sodium chloride.

..... [1]

(b) The electronic structures of an atom of sodium, Na , and of an atom of chlorine, Cl , are shown in Fig. 8.1.

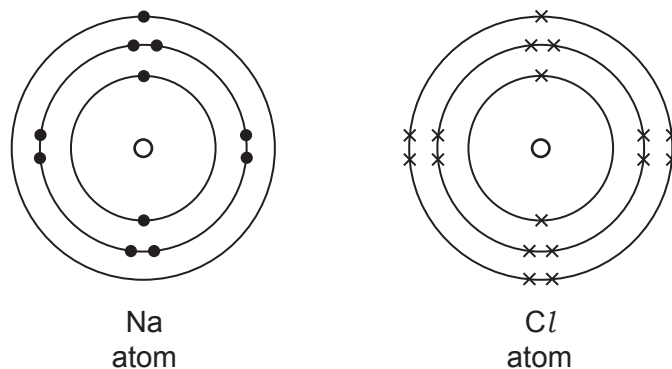

Fig. 8.1

Complete Fig. 8.2 to show the electronic structure of a sodium ion, Na^+ , and of a chloride ion, Cl^- .

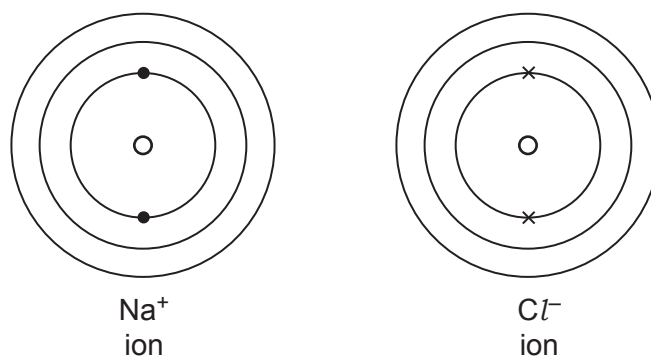

Fig. 8.2

[2]

- (c) Concentrated aqueous sodium chloride is electrolysed using inert electrodes, as shown in Fig. 8.3.

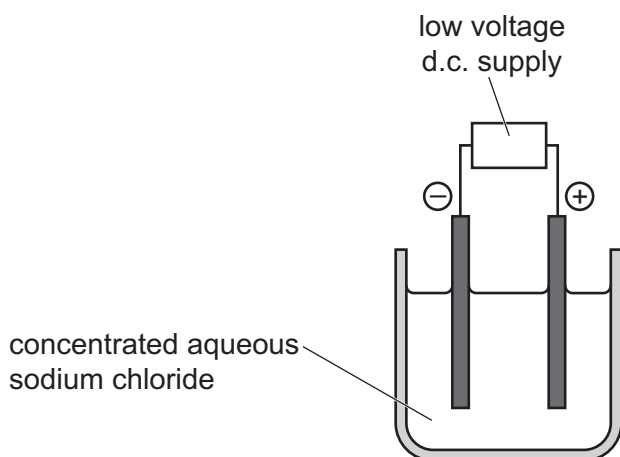

Fig. 8.3

Complete the word equation for the electrolysis of concentrated aqueous sodium chloride.



[2]

- (d) Suggest the pH of aqueous sodium hydroxide and its effect on the colour of Universal Indicator.

pH

colour

[2]

- (e) State the effect of chlorine gas on damp litmus paper.

..... [1]

[Total: 8]

9 Fig. 9.1 shows a police car. On the roof it has

- a flashing blue lamp that emits visible light
- a radio aerial to transmit radio waves.



Fig. 9.1

(a) (i) On Fig. 9.2 place radio waves and visible light in their correct positions in the incomplete electromagnetic spectrum.

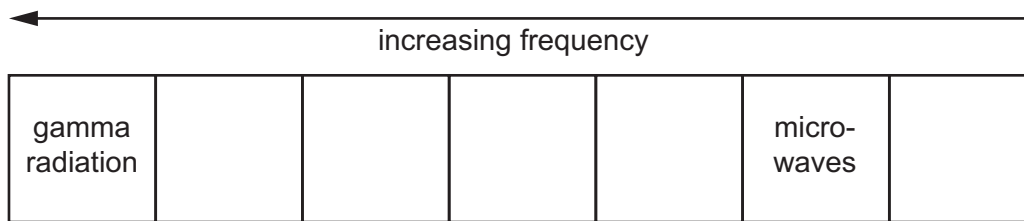

Fig. 9.2

[2]

(ii) State the meaning of the term *frequency*.

.....

..... [1]

(b) The resistance of the lamp when lit is $1.5\ \Omega$.

The battery supplies a voltage of 12V.

Calculate the current through the lamp when lit.

State the unit of your answer.

current = unit [3]

- (c) Complete Fig. 9.3 to show how a beam of light from the lamp is reflected from a plane mirror to an observer.

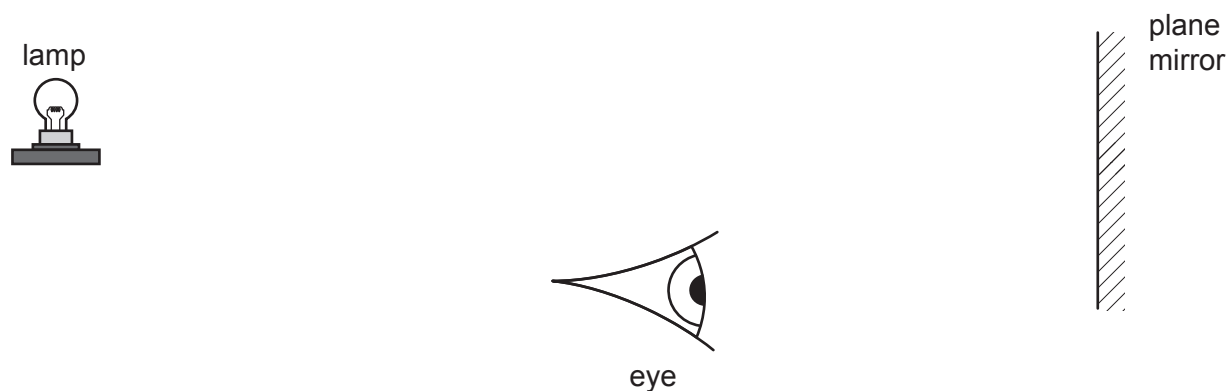

Fig. 9.3

[2]

- (d) The blue lamp is connected in series to the car battery and a switch.

On Fig. 9.4 complete the circuit diagram for the blue lamp.



Fig. 9.4

[2]

[Total: 10]

