



# Cambridge IGCSE™ (9–1)

CANDIDATE  
NAME

--

CENTRE  
NUMBER

--	--	--	--	--

CANDIDATE  
NUMBER

--	--	--	--

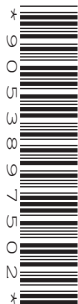

**CO-ORDINATED SCIENCES**

**0973/41**

Paper 4 Theory (Extended)

**May/June 2021**

**2 hours**

You must answer on the question paper.

No additional materials are needed.

## INSTRUCTIONS

- Answer **all** questions.
- Use a black or dark blue pen. You may use an HB pencil for any diagrams or graphs.
- Write your name, centre number and candidate number in the boxes at the top of the page.
- Write your answer to each question in the space provided.
- Do **not** use an erasable pen or correction fluid.
- Do **not** write on any bar codes.
- You may use a calculator.
- You should show all your working and use appropriate units.

## INFORMATION

- The total mark for this paper is 120.
- The number of marks for each question or part question is shown in brackets [ ].
- The Periodic Table is printed in the question paper.

This document has **28** pages. Any blank pages are indicated.

- 1 (a) Table 1.1 shows some features of aerobic and anaerobic respiration.

Place ticks (✓) in the boxes to show **all** the correct features for each type of respiration.

**Table 1.1**

type of respiration	oxygen is a reactant	glucose is a reactant	lactic acid is a product	carbon dioxide is a product
aerobic				
anaerobic respiration in muscles				
anaerobic respiration in yeast				

[4]

- (b) State **one** industrial use of anaerobic respiration in yeast.

..... [1]

- (c) Describe **one disadvantage** of anaerobic respiration in terms of energy release.

.....  
 ..... [1]

[Total: 6]

**BLANK PAGE**

2 Mixtures of coloured substances can be separated by paper chromatography.

(a) Fig. 2.1 shows how paper chromatography is used to separate a mixture of red and blue inks.

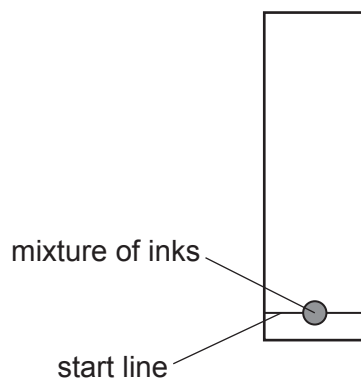

**Fig. 2.1**

(i) Explain why the start line is drawn in pencil rather than in ink.

.....

..... [1]

(ii) The result of the chromatography experiment is shown in Fig. 2.2.

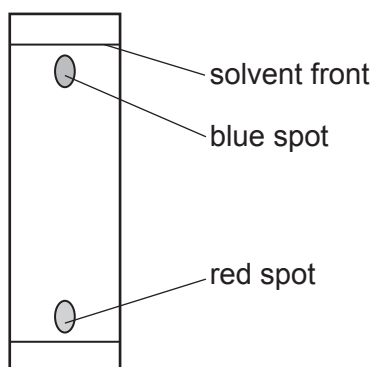

**Fig. 2.2**

The blue spot moves 14.2 cm and the solvent front moves 15.3 cm.

Calculate the  $R_f$  value of the substance in the blue spot.

Show your working.

$R_f$  value = ..... [2]

(b) **W, X, Y** and **Z** are mixtures of food colourings.

These mixtures of food colourings are investigated using paper chromatography.

The result of the chromatography experiment is shown in Fig. 2.3.

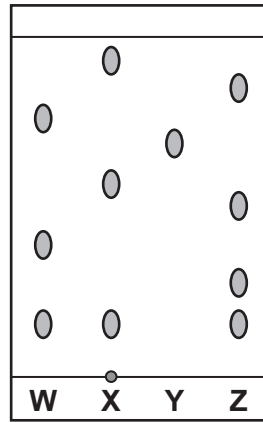

**Fig. 2.3**

(i) State which mixture contains an **insoluble** food colouring.

..... [1]

(ii) Explain which mixture is separated into the greatest number of soluble food colourings.

Refer to Fig. 2.3 in your answer.

.....  
 .....  
 ..... [2]

(c) A scientist tests the melting point of a sample of a substance.

The substance starts melting at 96 °C but does not melt completely until the temperature is 113 °C.

According to a data book, the melting point of the substance is 116 °C.

Explain, using the information given, if this sample of the substance is pure or impure.

.....  
 .....  
 ..... [2]

[Total: 8]

3 Fig. 3.1 shows a circuit used by a student to investigate the resistance of a metal wire.

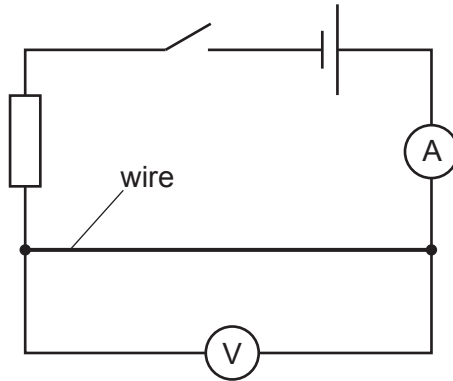

**Fig. 3.1**

(a) Suggest why a fixed resistor has been included in the circuit.

.....  
 ..... [1]

(b) When the switch is closed, the voltmeter reads 1.2V and the ammeter reads 0.40A.

(i) Calculate the resistance of the wire.

resistance = .....  $\Omega$  [2]

(ii) Calculate the amount of energy dissipated by the wire in 15 seconds.

State the unit of your answer.

energy = ..... unit = ..... [3]

(iii) State the energy transfer happening in the wire as current passes through it.

from ..... energy to ..... energy [1]

- (c) The wire is replaced with a second wire made of the same metal and of the same length but with twice the cross-sectional area.

Determine the resistance of the second wire.

resistance = .....  $\Omega$  [1]

- (d) The student wants to calculate the cross-sectional area of the wire.

State the quantity the student needs to measure **and** suggest a suitable measuring instrument to use.

quantity .....

measuring instrument .....

[2]

- (e) Fig. 3.2 shows the wire being placed in between the poles of a permanent magnet.

This causes a force to act on the wire.

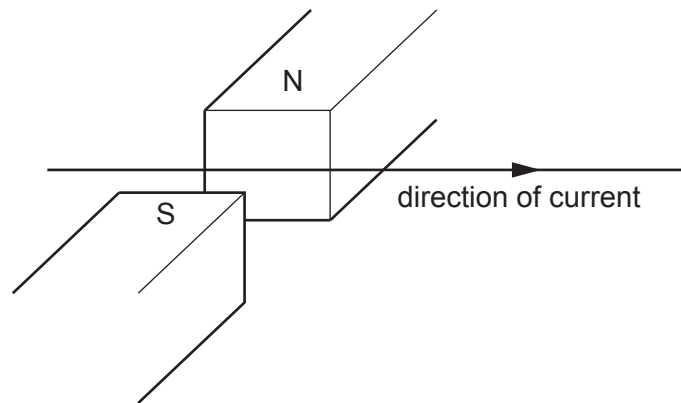

**Fig. 3.2**

- (i) Draw an arrow on Fig. 3.2 to show the direction of the force acting on the wire. [1]

- (ii) State two ways to increase the size of the force acting on the wire.

1 .....

.....

2 .....

.....

[2]

[Total: 13]

- 4 (a) Table 4.1 shows the vitamin D content in 100g of different foods.

**Table 4.1**

type of food	vitamin D content in 100g of food / $\mu\text{g}$
soya milk	1.3
cow milk	2.8
salmon	15.8
swordfish	19.8
tofu	4.0
mushroom	11.2

The recommended dietary allowance (RDA) of vitamin D is  $15.0\ \mu\text{g}$ .

Vegans do not eat any animal products and consume plant-based products such as tofu and soya milk.

- (i) Calculate the mass of tofu you would need to eat to get your RDA of vitamin D.

..... g [2]

- (ii) Explain why vegans may be more at risk of vitamin D deficiency than people who eat animal products.

Use the information in Table 4.1 in your answer.

.....  
 .....  
 .....  
 ..... [2]

- (b) Explain why pregnant women are recommended to increase their vitamin D intake.

.....  
 .....  
 .....  
 ..... [2]



(c) Name **one** disease caused by protein deficiency in the diet.

..... [1]

(d) Describe the chemical digestion of protein in the stomach.

.....  
.....  
.....  
.....  
..... [3]

(e) Describe how chemical digestion differs from mechanical digestion.

.....  
..... [1]

[Total: 11]

5 An atom of chlorine has a *proton number* (atomic number) of 17 and a *nucleon number* (mass number) of 37.

(a) (i) Complete Table 5.1 to show the numbers of protons, neutrons and electrons in this atom of chlorine.

Table 5.1

particle	number
proton	.....
neutron	.....
electron	.....

[3]

(ii) Chlorine is in Group VII of the Periodic Table.

State what information this gives about the number of electrons in the outer shell of a chlorine atom.

..... [1]

(iii) Chlorine exists as isotopes.

Explain what is meant by the term *isotopes*.

.....  
 .....  
 ..... [2]

(b) Chlorine atoms bond together to form the **covalent** molecule,  $Cl_2$ .

Chlorine,  $Cl_2$ , is a gas at room temperature.

Chlorine atoms bond with sodium atoms to form the **ionic** compound sodium chloride,  $NaCl$ .

Sodium chloride,  $NaCl$ , is a solid at room temperature.

Explain why chlorine is a gas but sodium chloride is a solid at room temperature in terms of attractive forces.

.....  
 .....  
 .....  
 ..... [3]

(c) Chlorine reacts with sodium bromide, NaBr.

Write the balanced symbol equation for this reaction.

..... [2]

[Total: 11]

6 Strontium-90 ( $^{90}\text{Sr}$ ) is a radioactive isotope.

(a) Strontium-90 decays by beta emission to form an isotope of yttrium and a  $\beta$ -particle.

(i) State the nature of a  $\beta$ -particle.

..... [1]

(ii) Use the correct nuclide notation to complete the symbol equation for this decay process.

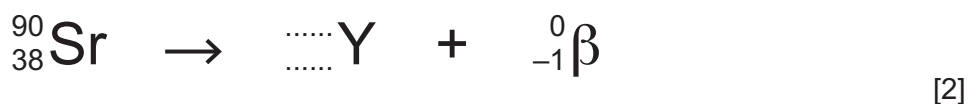

(b) Fig. 6.1 shows how this isotope of strontium can be used in a paper mill to determine the thickness of paper passing through a set of rollers.

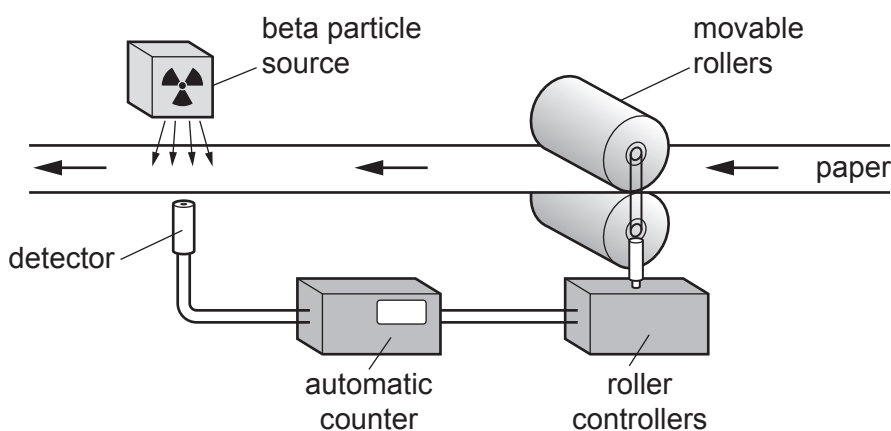

Fig. 6.1

Describe **and** explain what happens to the reading on the automatic counter if the paper becomes thicker.

.....

.....

.....

.....

.....

..... [2]

(c) Table 6.1 shows how the activity of a strontium source varies over a 60-year period.

**Table 6.1**

age of source /years	activity of source /counts per minute
0	2000
15	1400
30	1000
45	700
60	500

(i) Use Table 6.1 to determine the half-life of strontium-90.

..... [1]

(ii) Suggest why this half-life makes it suitable for use in a paper mill.

.....  
 ..... [1]

[Total: 7]

7 (a) Fig. 7.1 is a diagram of the human eye.

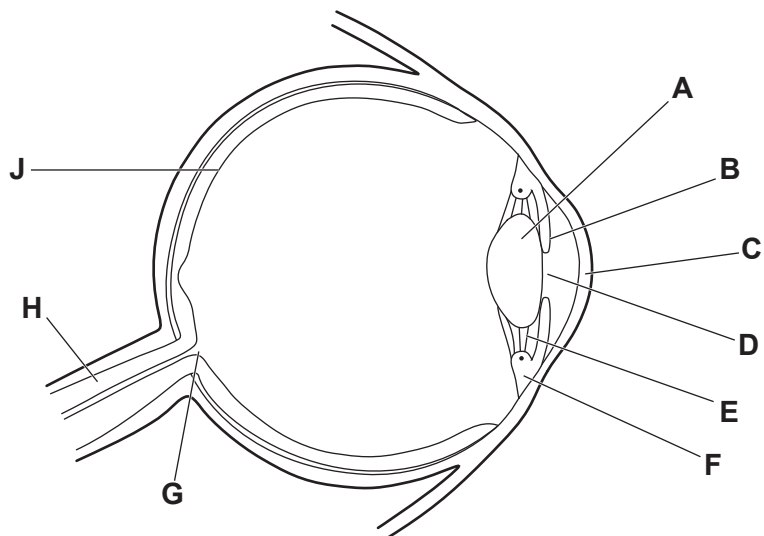

Fig. 7.1

- (i) Identify the letter on Fig. 7.1 that represents the part of the eye which:
  - carries impulses to the brain .....
  - refracts light as it enters the eye .....
  - controls how much light enters the eye. ....

[3]

- (ii) Describe what happens to parts **A**, **E** and **F** when someone changes from focusing on a distant object to focusing on a **near** object.

**A** .....

**E** .....

**F** .....

[3]

(b) The pupil reflex is a response to changes in light intensity.

- (i) Name the part of the eye that is the receptor in a pupil reflex.

..... [1]

- (ii) Name the part of the eye that is the effector in a pupil reflex.

..... [1]

(c) The pupil reflex is an involuntary action.

Place ticks (✓) next to **all** the examples of involuntary actions.

eating	
running	
sneezing	
sweating	
talking	

[2]

(d) Involuntary actions are controlled by the central nervous system.

Name both parts of the central nervous system.

..... and ..... [1]

[Total: 11]

8 Electrolysis is used to break down ionic compounds using electricity.

(a) Fig. 8.1 shows an electrolysis experiment.

Complete the labels on Fig. 8.1.

Choose your answers from the list.

**anion**

**anode**

**cation**

**cathode**

**electrolyte**

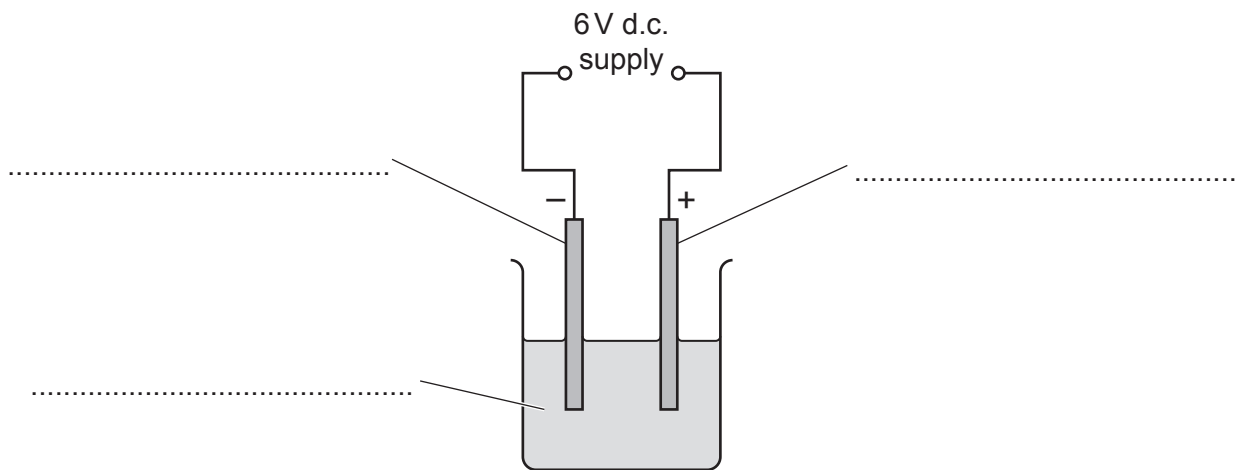

**Fig. 8.1**

[3]



(b) A student investigates the electrolysis of aqueous copper(II) sulfate using carbon electrodes.

Fig. 8.2 shows her experiment.

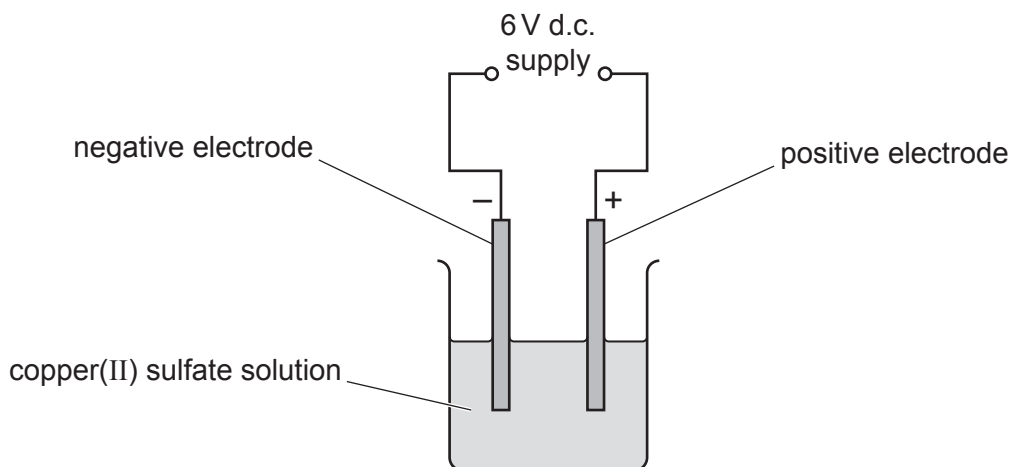

**Fig. 8.2**

(i) A gas is made at the positive electrode.

State the name of this gas.

..... [1]

(ii) At the negative electrode copper ions,  $\text{Cu}^{2+}$ , gain electrons to form copper metal, Cu.

Construct the ionic half-equation for the formation of copper at the negative electrode.

Use  $e^-$  to represent an electron.

..... [2]

- (c) In the electrolysis of molten lead(II) bromide, bromine is formed at the positive electrode.

The ionic half-equation is shown.



- (i) State, in terms of electrons, if this reaction is oxidation or reduction.

Explain your answer.

statement .....

explanation .....

.....

[1]

- (ii) The total mass of bromine gas made in an electrolysis experiment is 20g.

Calculate the volume of bromine gas made.

The volume of one mole of any gas is  $24 \text{ dm}^3$  at room temperature and pressure (r.t.p.).

Show your working.

[ $A_r$ : Br, 80]

volume of bromine gas = .....  $\text{dm}^3$  [3]

[Total: 10]

9 Fig. 9.1 shows the motion of a sprinter running a race.

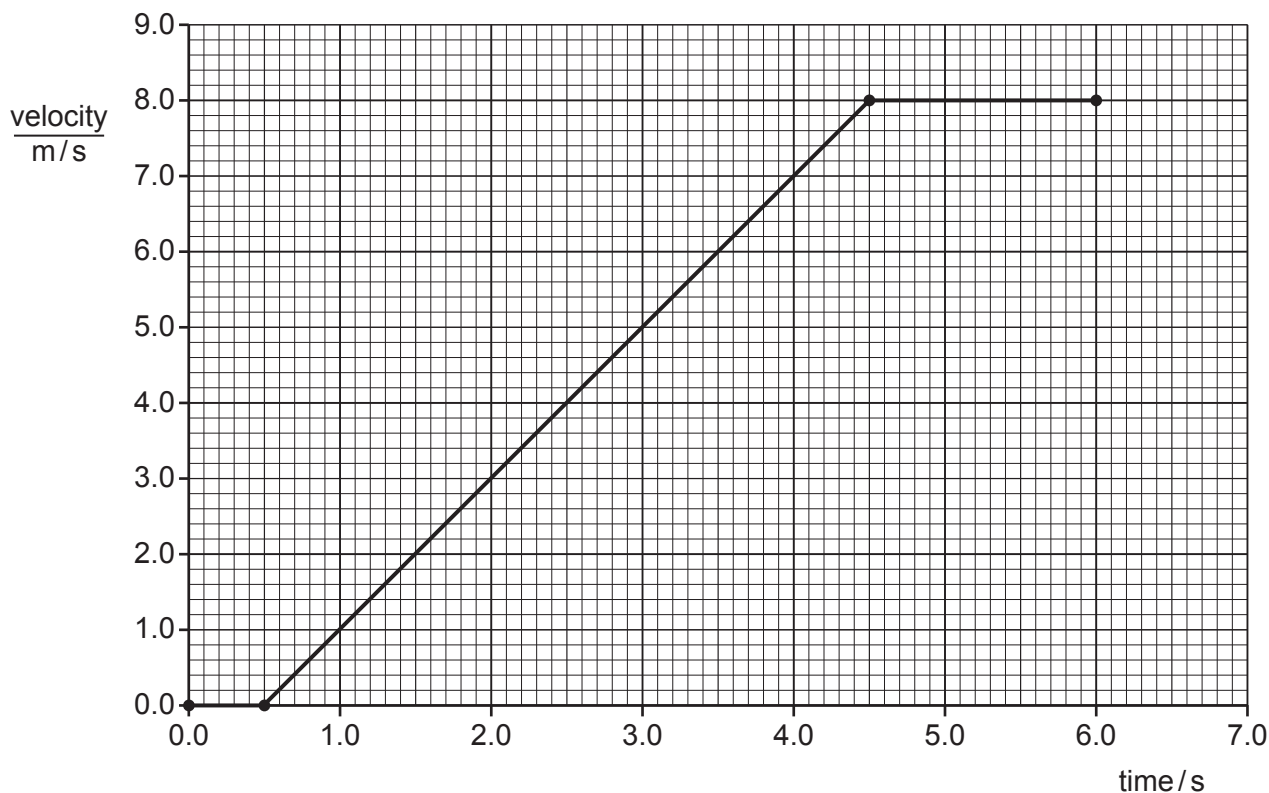

Fig. 9.1

(a) Describe the motion of the sprinter during the first 0.5 seconds of the race.

.....  
 ..... [1]

(b) Show that the maximum acceleration of the sprinter is  $2.0 \text{ m/s}^2$ .

[1]

(c) This acceleration is caused by a resultant force of 160 N.

Calculate the mass of the sprinter.

mass = ..... kg [2]

(d) Fig. 9.2 shows the forces acting on the sprinter at various points during the race.

The lengths of the arrows represent the magnitude of the forces.

(i) Put a tick (✓) in the box which shows the horizontal forces acting on the sprinter 5.0 s after the race started.

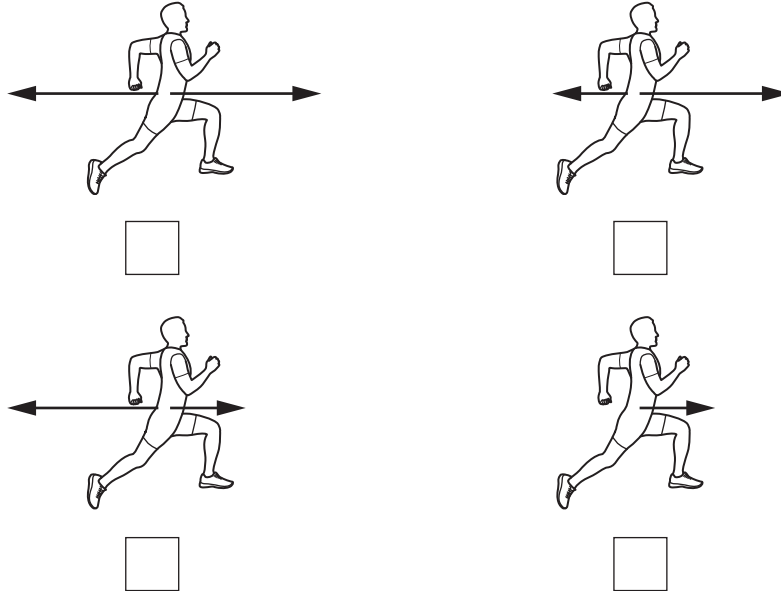

Fig. 9.2

[1]

(ii) Use the motion of the sprinter in Fig. 9.1 to explain your answer to (d)(i).

.....  
.....  
..... [1]

(e) At the end of the race, the sprinter's skin is coated in a layer of sweat.

(i) Describe, in terms of particles and their energies, how the sweat cools the skin.

.....  
.....  
.....  
.....  
..... [3]

(ii) Describe two differences between evaporation and boiling.

1 .....  
.....  
2 .....  
..... [2]

[Total: 11]

10 (a) Fig. 10.1 is a flowchart showing the process of eutrophication.

Complete the flowchart in Fig. 10.1.

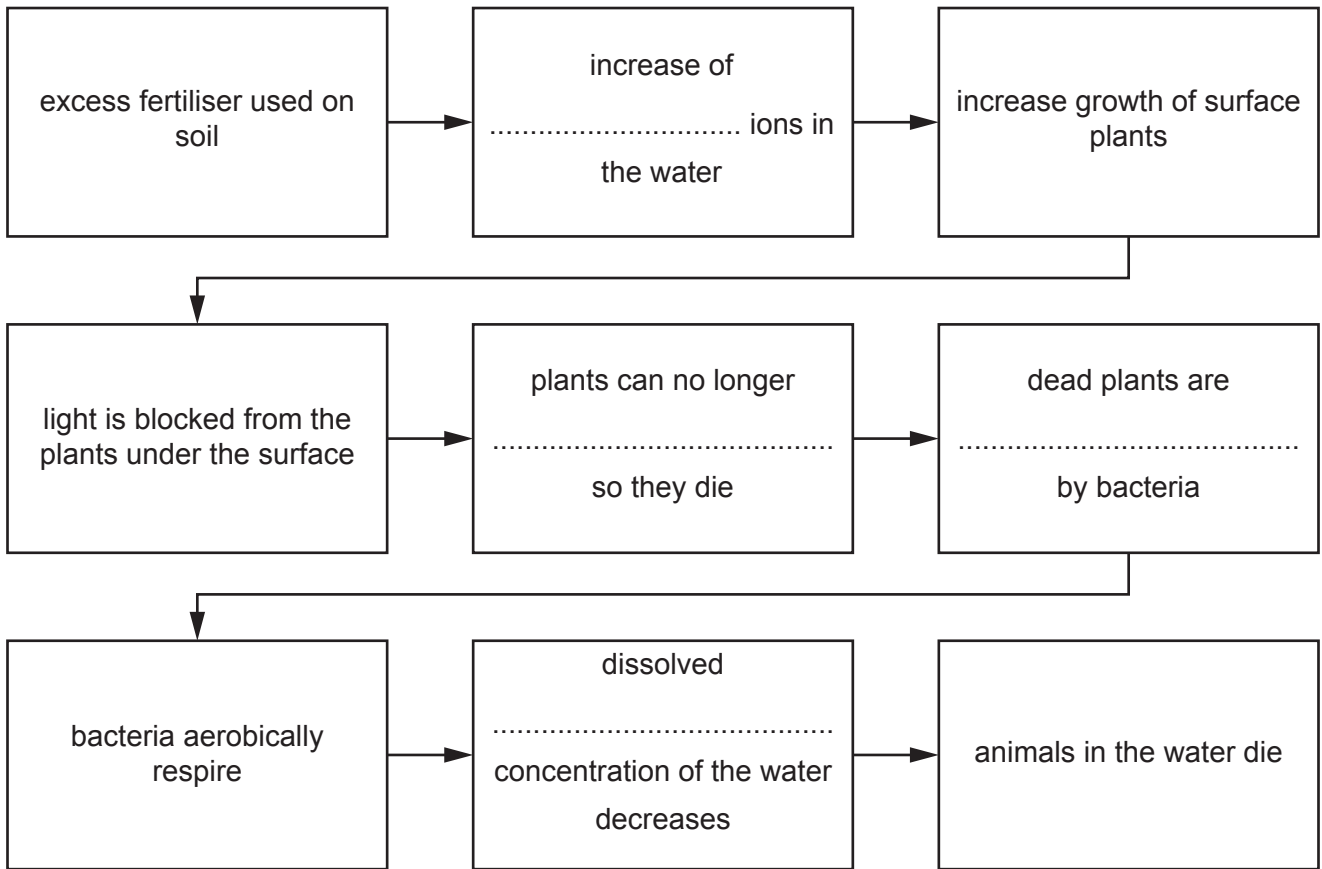

Fig. 10.1

[4]

(b) Deforestation can result in increased eutrophication, especially when it rains.

Suggest why deforestation causes an increase in eutrophication.

.....

.....

.....

..... [2]

(c) List two undesirable effects of deforestation on animals living in the forest.

1 .....

2 .....

[2]

(d) Trees make their own organic nutrients through photosynthesis.

State the term used to describe organisms that make their own nutrients.

..... [1]

(e) List three **substances** plants need to make their own organic nutrients.

1 .....

2 .....

3 .....

[3]

[Total: 12]

11 Ethene and propene are both members of the homologous series called the alkenes.

Fig. 11.1 shows the structures of ethene and propene.

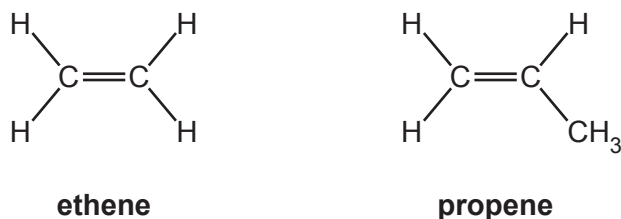

Fig. 11.1

(a) State two reasons why ethene and propene are members of the same homologous series.

reason 1 .....

.....

reason 2 .....

.....

[2]

(b) Ethene can be made by the cracking of large alkane molecules.

(i) State the conditions needed for cracking.

1 .....

2 .....

[2]

(ii) Ethene,  $C_2H_4$ , can be made by the cracking of octane,  $C_8H_{18}$ .

The balanced symbol equation for the reaction is shown.

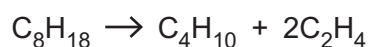

State the name of the other product made and complete Fig. 11.2 to show its structure.

Show all the covalent bonds.

name .....

structure



Fig. 11.2

[3]



(c) Ethene reacts with bromine, Br<sub>2</sub>, in an addition reaction.

Write the balanced symbol equation for this reaction.

..... [2]

(d) Propene forms poly(propene) in an **addition polymerisation** reaction.

Complete the structure of poly(propene).

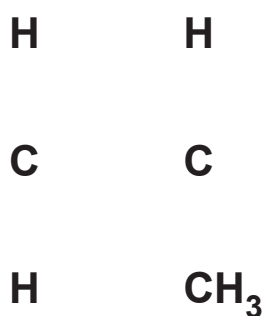

[1]

(e) Nylon is a polymer made in a **condensation** polymerisation reaction.

Complete the equation to show the formation of nylon.

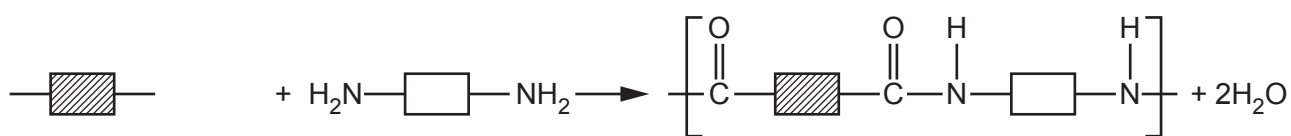

[1]

[Total: 11]

12 A student plans to measure the speed of sound through wood.

The student places a microphone at one end of a wooden desk and knocks loudly on the other end of the desk with a hammer.

She measures the time it takes for the sound to travel through the desk to the microphone.

(a) It takes 1.5 ms for the sound to travel 6.0 m through the wooden desk.

Calculate the speed of sound in wood.

speed = ..... m/s [3]

(b) Explain, in terms of particles, why the speed of sound in wood is much greater than the speed of sound in air.

.....  
 .....  
 ..... [3]

(c) Sound is an example of a longitudinal wave.

State what is meant by a longitudinal wave.

.....  
 ..... [1]

(d) When a wave travels through a gap similar in size to its wavelength, diffraction occurs.

Complete Fig. 12.1 to show diffraction of a sound wave through a doorway.

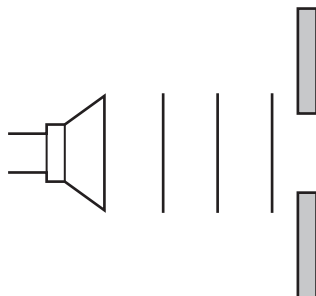

Fig. 12.1

[2]

[Total: 9]

**BLANK PAGE**

---

Permission to reproduce items where third-party owned material protected by copyright is included has been sought and cleared where possible. Every reasonable effort has been made by the publisher (UCLES) to trace copyright holders, but if any items requiring clearance have unwittingly been included, the publisher will be pleased to make amends at the earliest possible opportunity.

To avoid the issue of disclosure of answer-related information to candidates, all copyright acknowledgements are reproduced online in the Cambridge Assessment International Education Copyright Acknowledgements Booklet. This is produced for each series of examinations and is freely available to download at [www.cambridgeinternational.org](http://www.cambridgeinternational.org) after the live examination series.

Cambridge Assessment International Education is part of the Cambridge Assessment Group. Cambridge Assessment is the brand name of the University of Cambridge Local Examinations Syndicate (UCLES), which itself is a department of the University of Cambridge.

## The Periodic Table of Elements

Group									
I	II	III	IV	V	VI	VII	VIII		
3 <b>Li</b> lithium 7	4 <b>Be</b> beryllium 9	1 <b>H</b> hydrogen 1	5 <b>B</b> boron 11	6 <b>C</b> carbon 12	7 <b>N</b> nitrogen 14	8 <b>O</b> oxygen 16	9 <b>F</b> fluorine 19	10 <b>Ne</b> neon 20	2 <b>He</b> helium 4
11 <b>Na</b> sodium 23	12 <b>Mg</b> magnesium 24	<b>Key</b> atomic number atomic symbol name relative atomic mass		13 <b>Al</b> aluminium 27	14 <b>Si</b> silicon 28	15 <b>P</b> phosphorus 31	16 <b>S</b> sulfur 32	17 <b>Cl</b> chlorine 35.5	18 <b>Ar</b> argon 40
19 <b>K</b> potassium 39	20 <b>Ca</b> calcium 40	25 <b>Mn</b> manganese 55	26 <b>Fe</b> iron 56	27 <b>Co</b> cobalt 59	28 <b>Ni</b> nickel 59	29 <b>Cu</b> copper 64	30 <b>Zn</b> zinc 65	33 <b>As</b> arsenic 75	34 <b>Se</b> selenium 79
37 <b>Rb</b> rubidium 85	38 <b>Sr</b> strontium 88	43 <b>Tc</b> technetium —	44 <b>Ru</b> ruthenium 101	45 <b>Rh</b> rhodium 103	46 <b>Pd</b> palladium 106	47 <b>Ag</b> silver 108	48 <b>Cd</b> cadmium 112	51 <b>Sb</b> antimony 122	52 <b>Te</b> tellurium 128
55 <b>Cs</b> caesium 133	56 <b>Ba</b> barium 137	75 <b>Re</b> rhenium 186	76 <b>Os</b> osmium 190	77 <b>Ir</b> iridium 192	78 <b>Pt</b> platinum 195	79 <b>Au</b> gold 197	80 <b>Hg</b> mercury 201	83 <b>Bi</b> bismuth 209	84 <b>Po</b> polonium —
87 <b>Fr</b> francium —	88 <b>Ra</b> radium —	107 <b>Bh</b> bohrium —	108 <b>Hs</b> hassium —	109 <b>Mt</b> meitnerium —	110 <b>Ds</b> darmstadtium —	111 <b>Rg</b> roentgenium —	112 <b>Cn</b> copernicium —	116 <b>Lv</b> livermorium —	86 <b>Rn</b> radon —
21 <b>Sc</b> scandium 45	22 <b>Ti</b> titanium 48	23 <b>V</b> vanadium 51	24 <b>Cr</b> chromium 52	25 <b>Mn</b> manganese 55	26 <b>Fe</b> iron 56	27 <b>Co</b> cobalt 59	28 <b>Ni</b> nickel 59	29 <b>Cu</b> copper 64	30 <b>Zn</b> zinc 65
39 <b>Y</b> yttrium 89	40 <b>Zr</b> zirconium 91	41 <b>Nb</b> niobium 93	42 <b>Mo</b> molybdenum 96	43 <b>Tc</b> technetium —	44 <b>Ru</b> ruthenium 101	45 <b>Rh</b> rhodium 103	46 <b>Pd</b> palladium 106	47 <b>Ag</b> silver 108	48 <b>Cd</b> cadmium 112
57–71 lanthanoids	72 <b>Hf</b> hafnium 178	73 <b>Ta</b> tantalum 181	74 <b>W</b> tungsten 184	75 <b>Re</b> rhenium 186	76 <b>Os</b> osmium 190	77 <b>Ir</b> iridium 192	78 <b>Pt</b> platinum 195	79 <b>Au</b> gold 197	80 <b>Hg</b> mercury 201
89–103 actinoids	104 <b>Rf</b> rutherfordium —	105 <b>Db</b> dubnium —	106 <b>Sg</b> seaborgium —	107 <b>Bh</b> bohrium —	108 <b>Hs</b> hassium —	109 <b>Mt</b> meitnerium —	110 <b>Ds</b> darmstadtium —	111 <b>Rg</b> roentgenium —	112 <b>Cn</b> copernicium —

lanthanoids

actinoids

57 <b>La</b> lanthanum 139	58 <b>Ce</b> cerium 140	59 <b>Pr</b> praseodymium 141	60 <b>Nd</b> neodymium 144	61 <b>Pm</b> promethium —	62 <b>Sm</b> samarium 150	63 <b>Eu</b> europium 152	64 <b>Gd</b> gadolinium 157	65 <b>Tb</b> terbium 159	66 <b>Dy</b> dysprosium 163	67 <b>Ho</b> holmium 165	68 <b>Er</b> erbium 167	69 <b>Tm</b> thulium 169	70 <b>Yb</b> ytterbium 173	71 <b>Lu</b> lutetium 175
89 <b>Ac</b> actinium —	90 <b>Th</b> thorium 232	91 <b>Pa</b> protactinium 231	92 <b>U</b> uranium 238	93 <b>Np</b> neptunium —	94 <b>Pu</b> plutonium —	95 <b>Am</b> americium —	96 <b>Cm</b> curium —	97 <b>Bk</b> berkelium —	98 <b>Cf</b> californium —	99 <b>Es</b> einsteinium —	100 <b>Fm</b> fermium —	101 <b>Md</b> mendelevium —	102 <b>No</b> nobelium —	103 <b>Lr</b> lawrencium —

The volume of one mole of any gas is 24 dm<sup>3</sup> at room temperature and pressure (r.t.p.).